

KURKO KOPONEN

NOSTOPALVELUIDEN ASIAANTUNTIJA



KALUSTOKATALOGI

KOKO MAAN KURKO

NOSTA LUURI, ME NOSTAMME LOPUT

Tarjoamme laadukkaita nostoalan palveluja koko Suomen alueella. Hyvän palvelumme perusta on yli 60 vuoden kokemus, asianmukainen kalusto, huolelliset nostosuunnitelmat sekä osaavat ihmiset. Vuosikymmenten myötä tyytyväiset vakioasiakkaamme ovat kiittäneet toimintavarmuuttamme.

Me palvelemme kaikkia asiakkaitamme isältä pojalle siirtyneen perheyriksen tinkimättömyydellä.

Kurko-Koponen Oy:llä on kattava valikoima eri nostotekoisia asennusnosturiautoja, mobiilnostureita, teollisuusnostureita sekä mininostureita ja niiden lisävarusteita. Lisäksi käytämme yhteistyökumppaneita.

Meiltä saat oikean kaluston, oikeaan aikaan, oikeaan paikkaan.



Yrityksessämme on käytössä sertifioitu laatu järjestelmä ISO 9001/2015, sertifioinnin on suorittanut Det Norske Veritas.

Yrityksemme todistukset löytyvät osoitteesta www.tilajavastuu.fi. Kurko-Koponen Oy on INFRA RY:n jäsenyrius. Käytämme nostotoissa Infra Ry:n ajoneuvonostureiden yleisiä vuokrausehtoja.

Lisätietoja: www.infrary.fi.

Tilaa Kurko-nosturi paikalle:
Puh. 029 170 1400
www.kurkokoponen.fi

Sisällysluettelo

KALUSTOLUETTELO

◆ 215 T/M PERÄASETEINEN PITKÄPUOMINOSTURIAUTO	4
◆ 215 T/M PITKÄPUOMINOSTURIAUTO	5
◇ Tuotekuvia	8
◆ 195 T/M PITKÄPUOMINOSTURIAUTO	10
◆ 165 T/M PITKÄPUOMINOSTURIAUTO	14
◆ 165 T/M NOSTURIAUTO	18
◆ 165 T/M NOSTURIAUTO	22
◇ TUOTEKUVIA	24
◆ 155 T/M NOSTURIAUTO	26
◆ 135 T/M NOSTURIAUTO	30
◆ 115 T/M NOSTURIAUTO	32
◆ 90 T/M NOSTURIAUTO	36
◆ 99 T/M NOSTURIAUTO	38
◇ TUOTEKUVIA	42
◆ 95 t/m nosturiauto	44
◆ 92 T/M NOSTURIAUTO	50
◆ 230 TN MOBIILINOSTURI	52
◆ 150 tn mobiilnosturi	56
◆ 95 tn mobiilnosturi	60
◇ tuotekuvia	64
◆ Priimus, 8 t/m mininosturi	66
◆ JEKKO JF545	68
◇ Tuotekuvia	70
◇ LISÄVARUSTEET	74
◇ Historia	78
◆ YMPÄRISTÖVASTUULLISUUS	81

Kalustoluettelossa mainitut mitat, painot ja nostoarvot ovat suuntaa-antavia.

215 t/m peräasenteinen pitkäpuominosturiauto

42000 kg	9800 mm	46,4 m	3792 mm
10310 mm	10990 mm	50 m	2550 mm

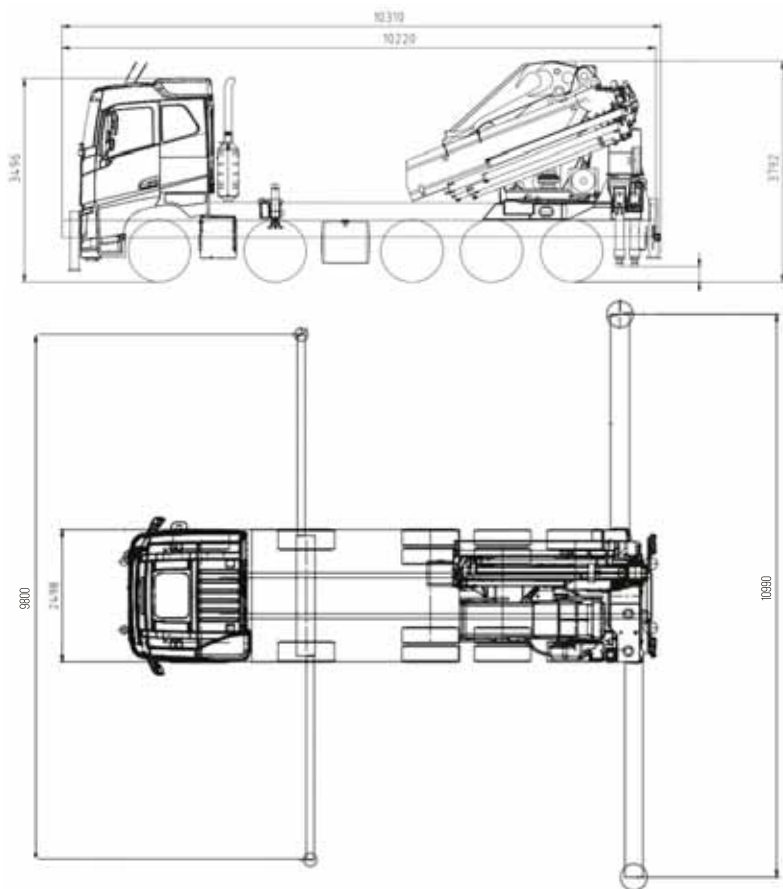

215 t/m pitkäpuominosturiauto

38600 kg	10990 mm	46,4 m	3800 mm
11840 mm	10000 mm	50 m	2550 mm

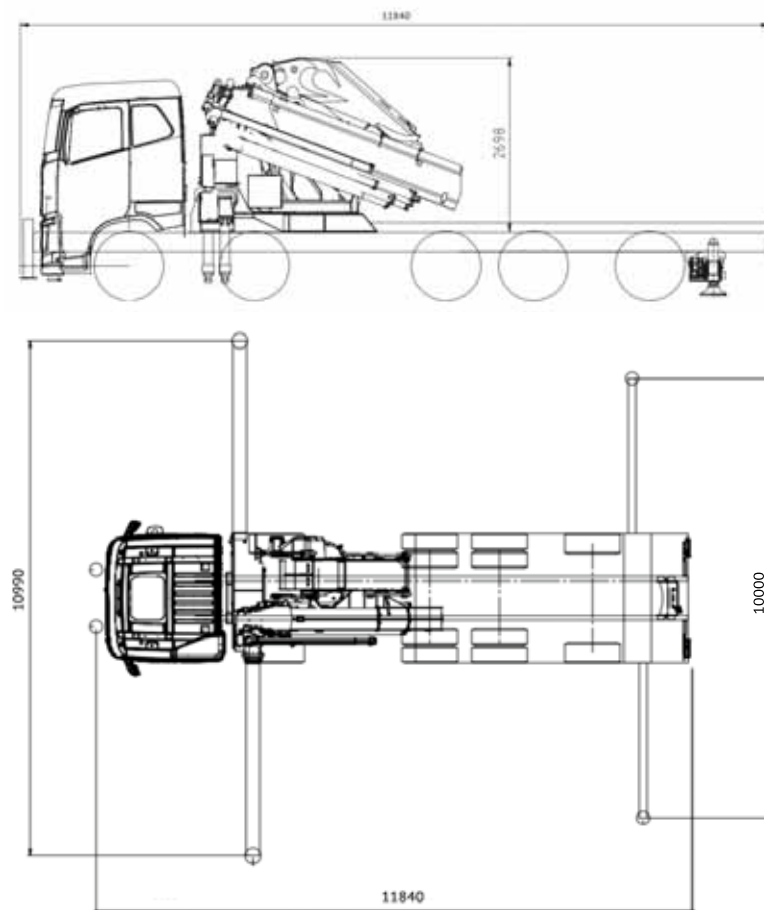

215 t/m pitkäpuominosturiauto

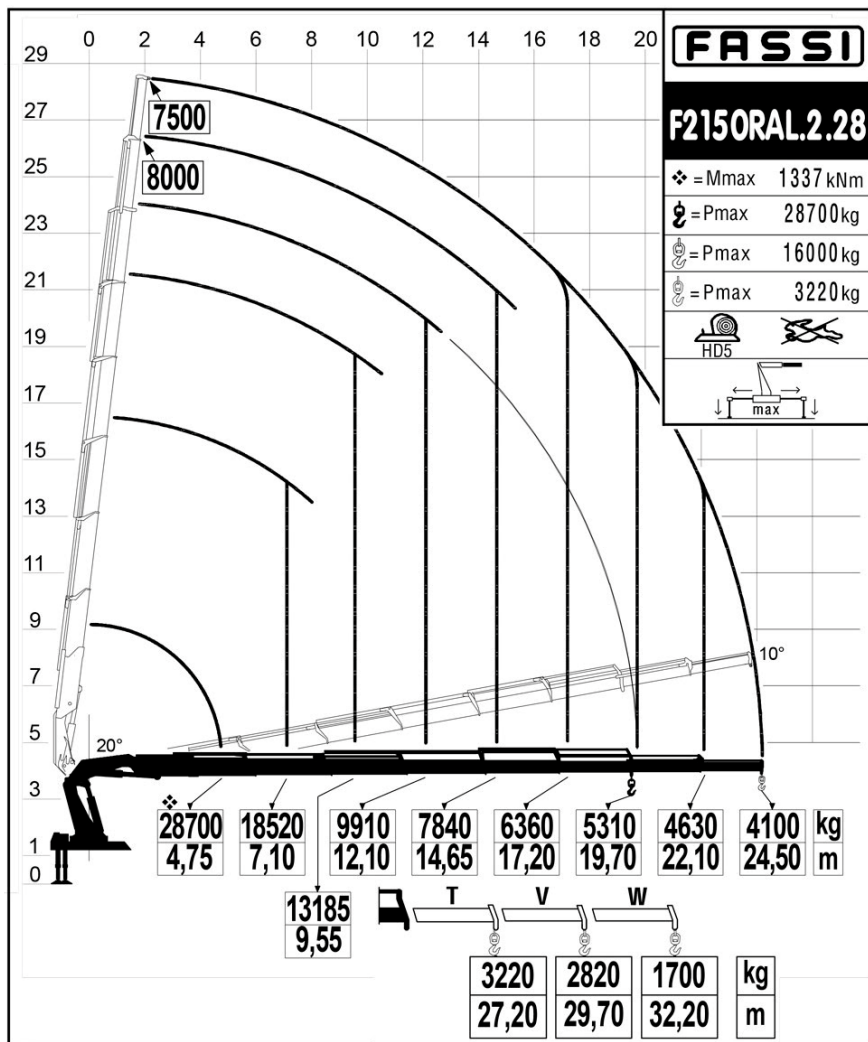

215 t/m pitkäpuominosturiauto

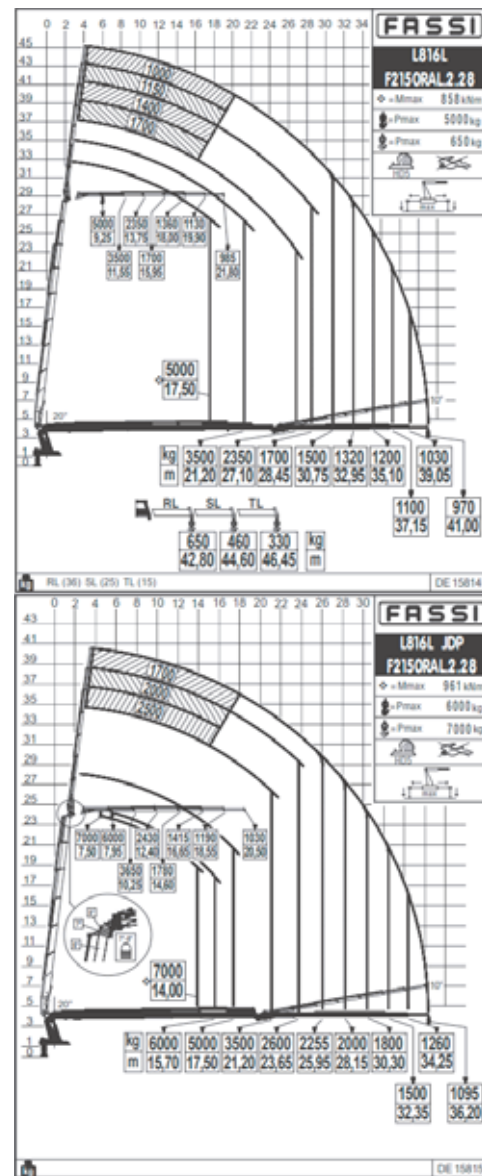



◆ 195 t/m pitkäpuominosturiauto

39200 kg	10990 mm	46,4 m	3800 mm
11731 mm	10000 mm	50 m	2550 mm

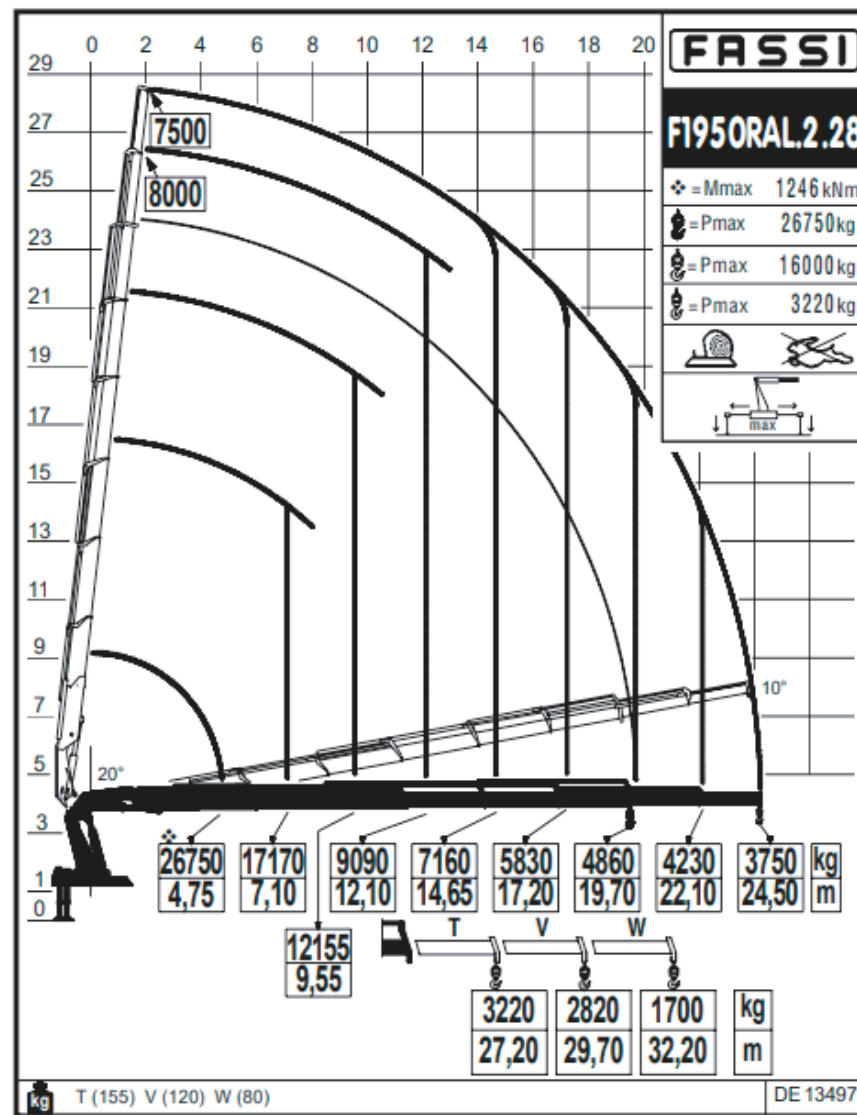
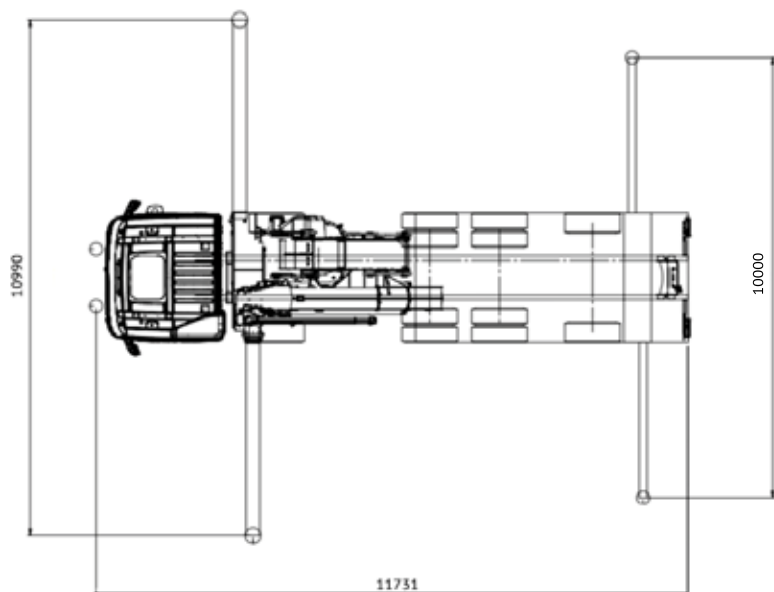
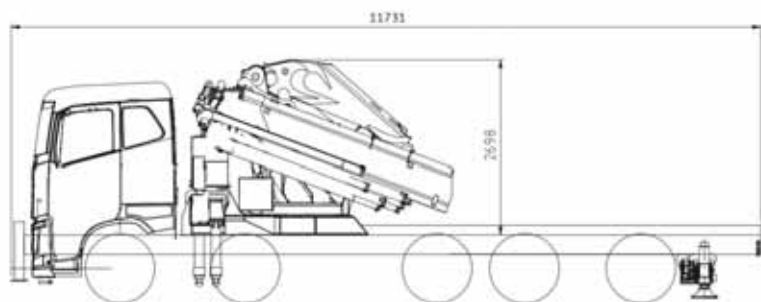

◆ 195 t/m pitkäpuominosturiauto

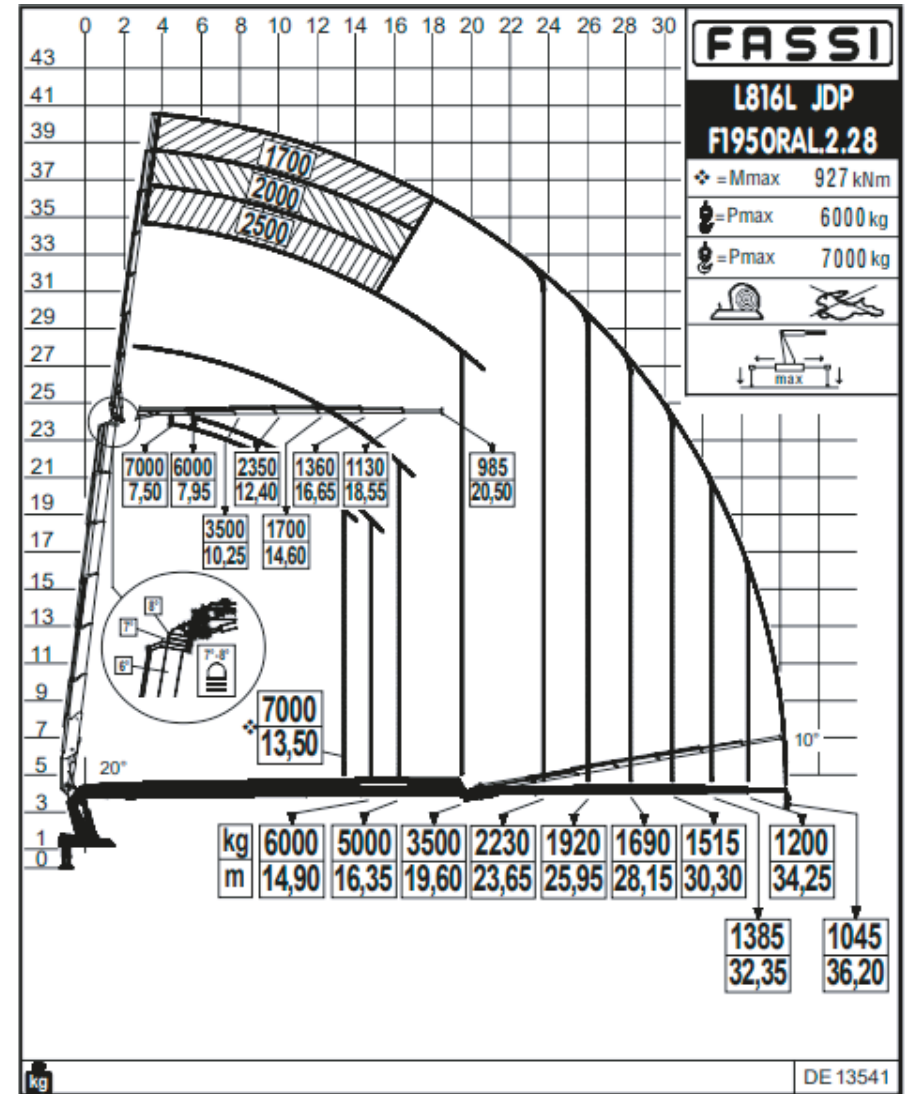
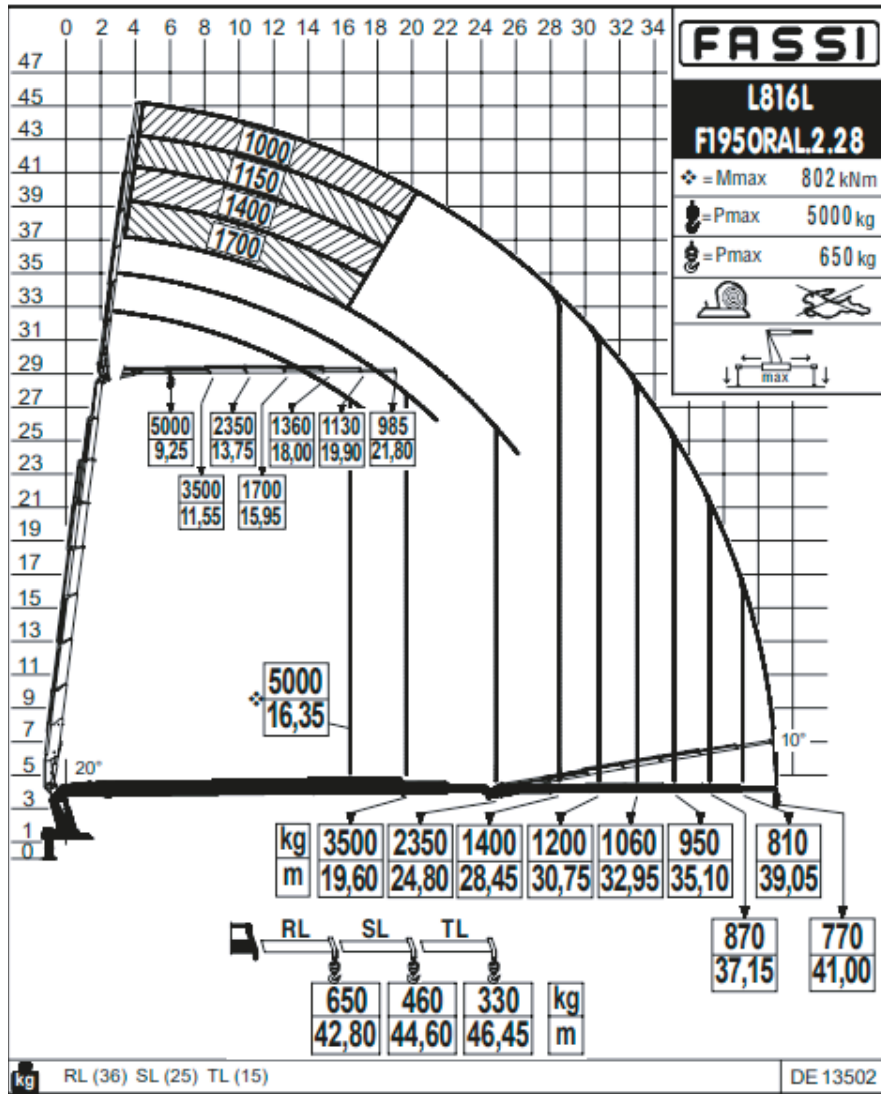

◆ 165 t/m pitkäpuominosturiauto

39000 kg	9960 mm	46 m	3850 mm
11830 mm	8500 mm	50 m	2550 mm

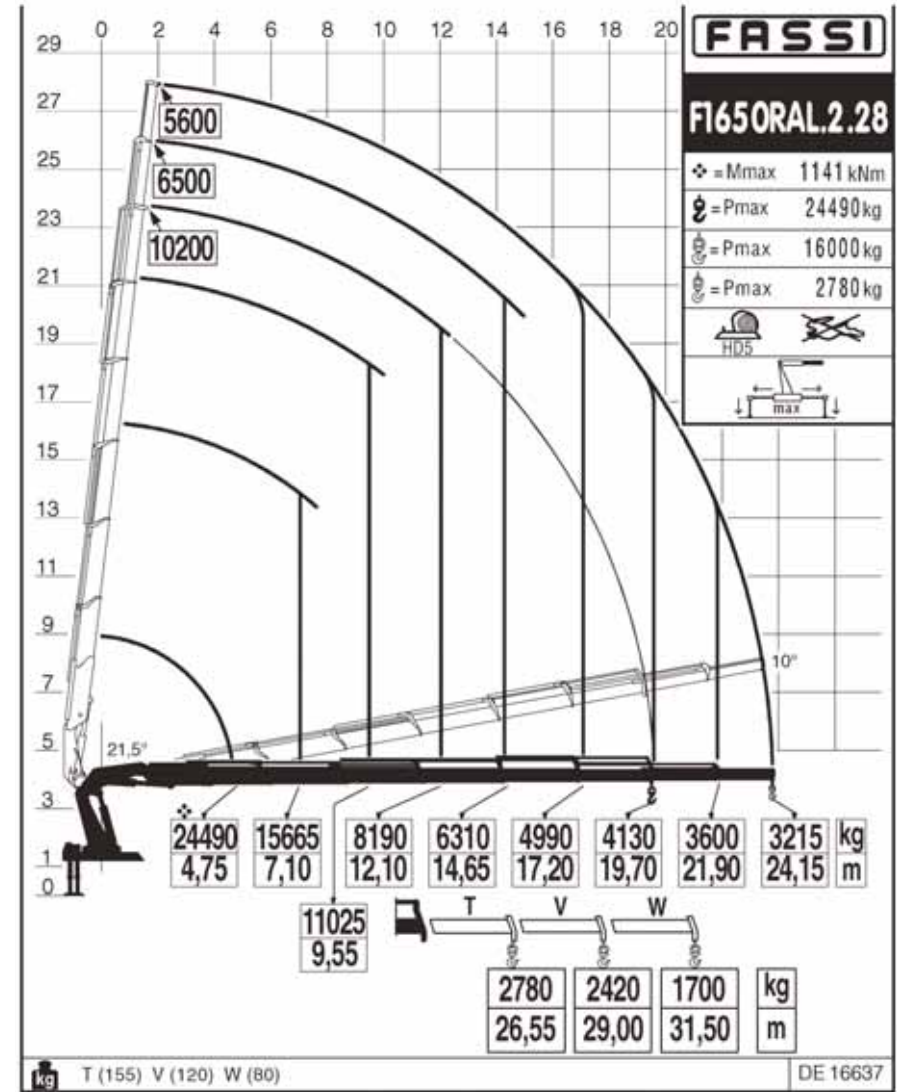
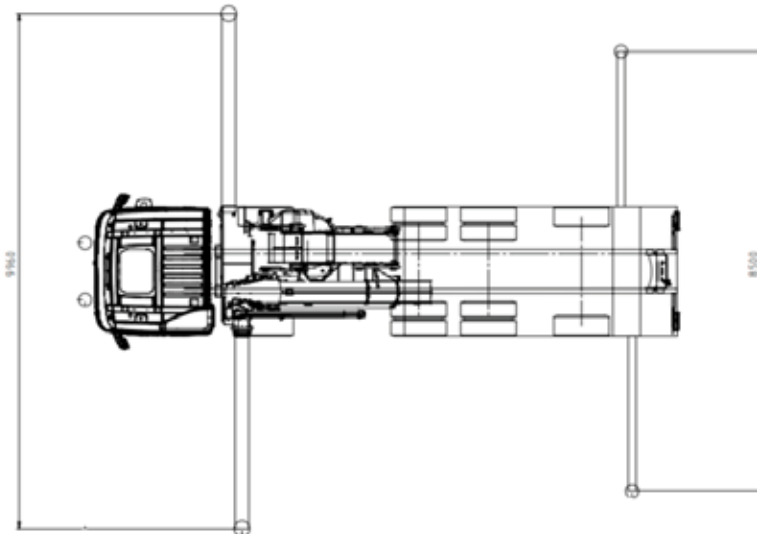
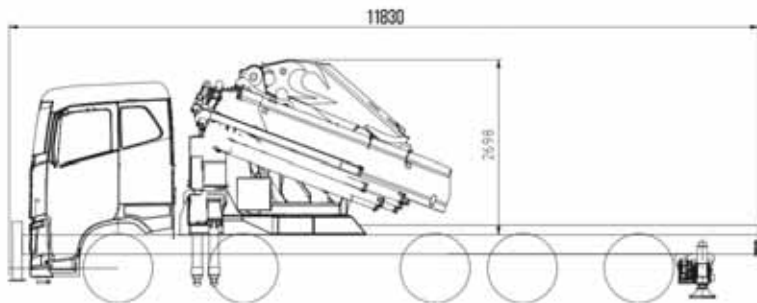

◆ 165 t/m pitkäpuominosturiauto

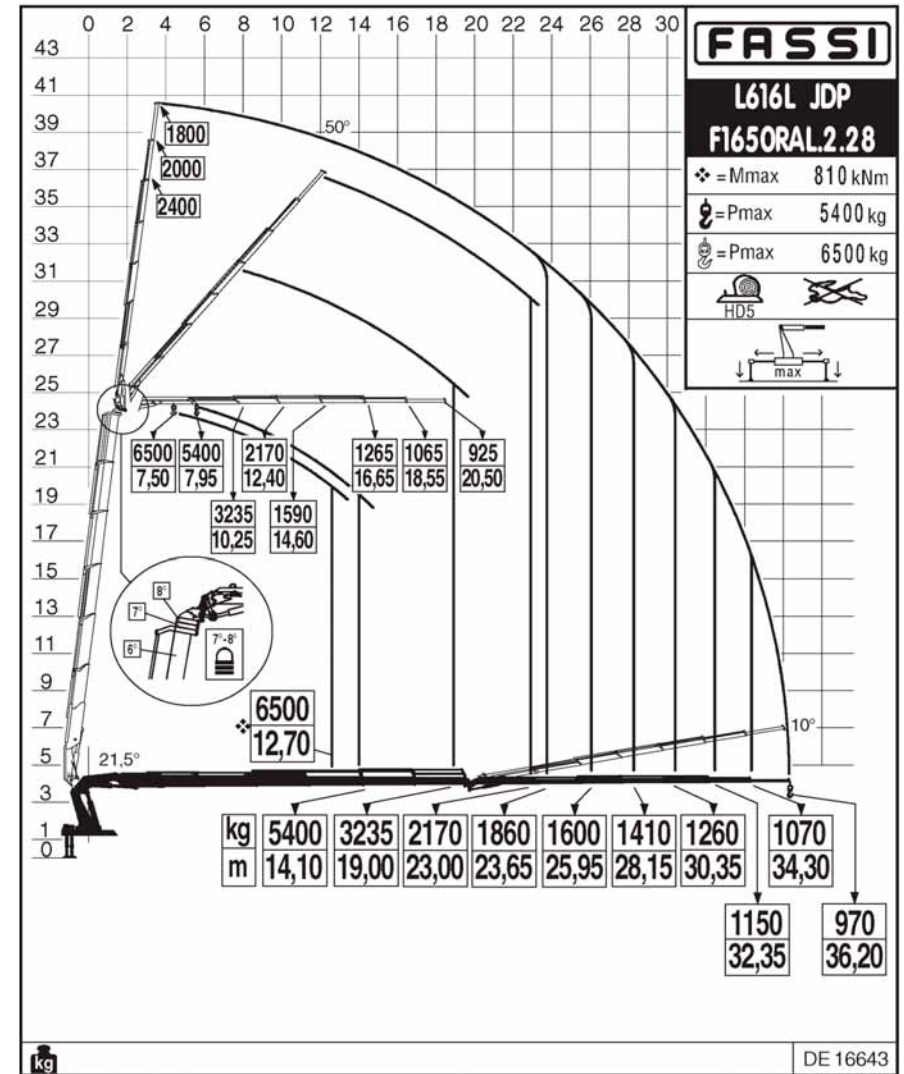
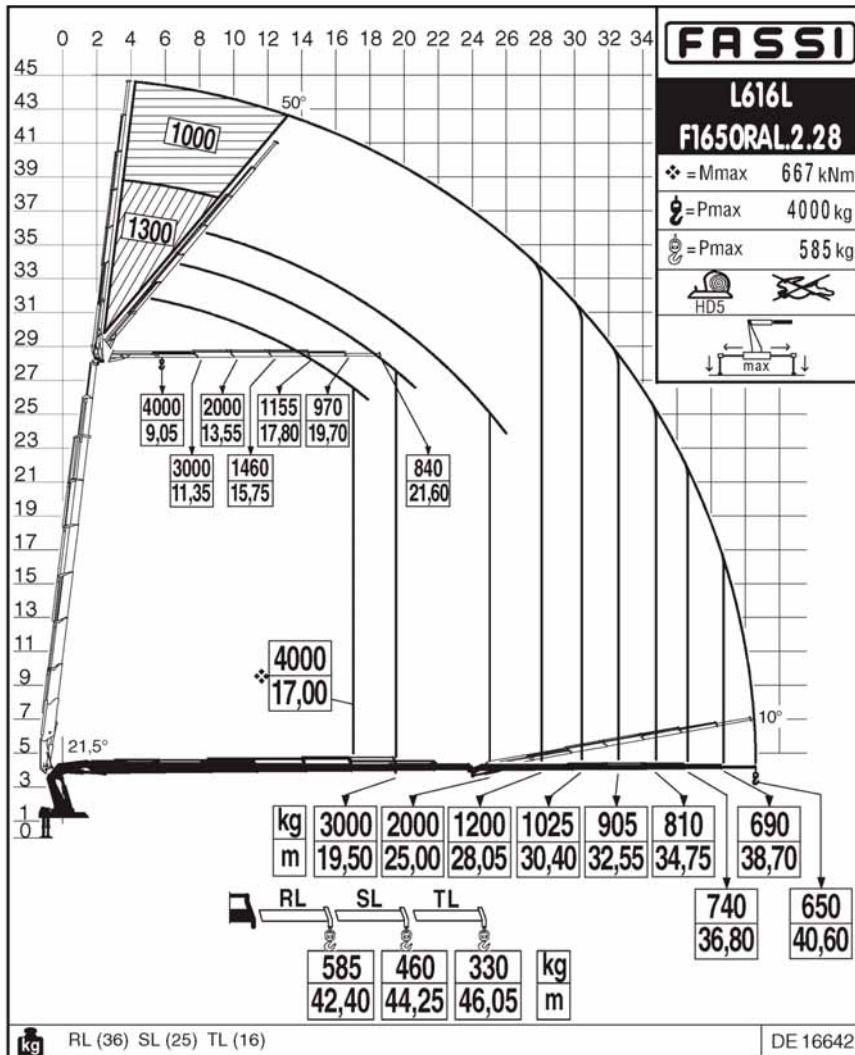

◆ 165 t/m nosturiauto

36400 KG	9960 mM	36,7 m	3800 mm
11490 mM	8500 mM	40 m	2550 mM

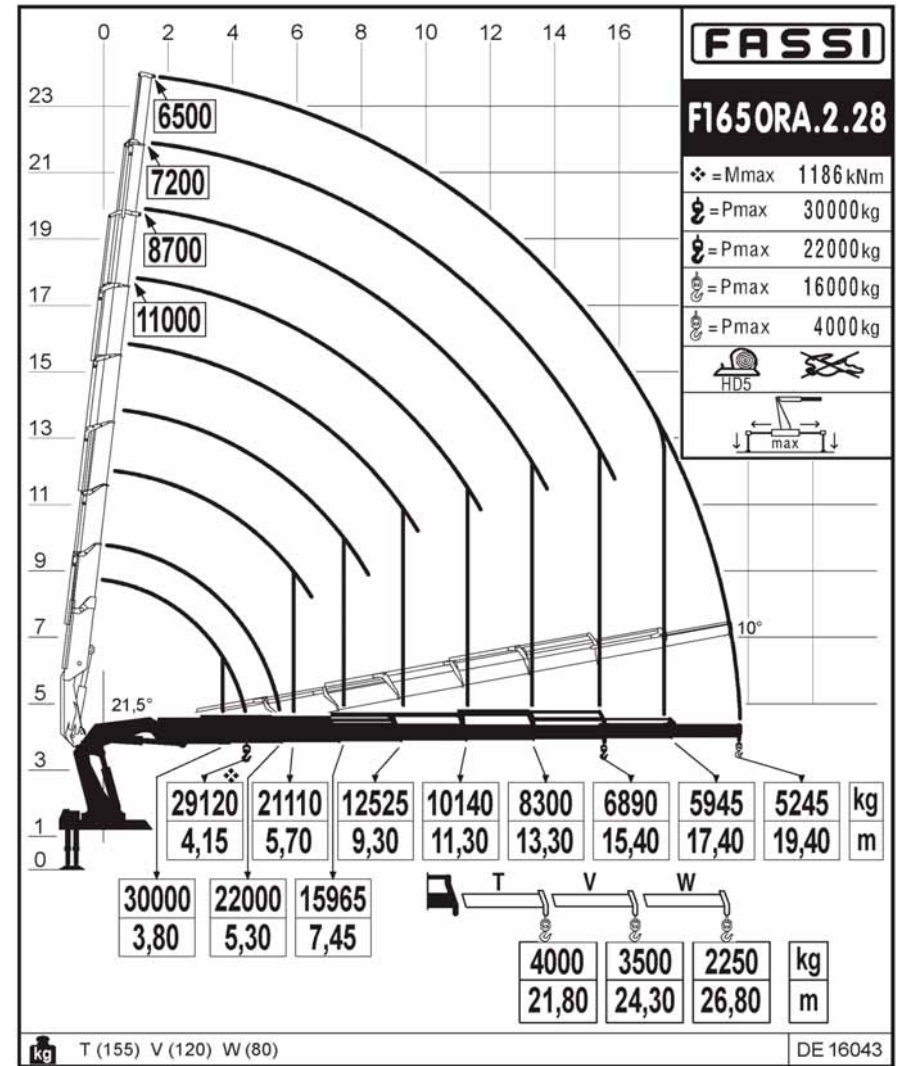
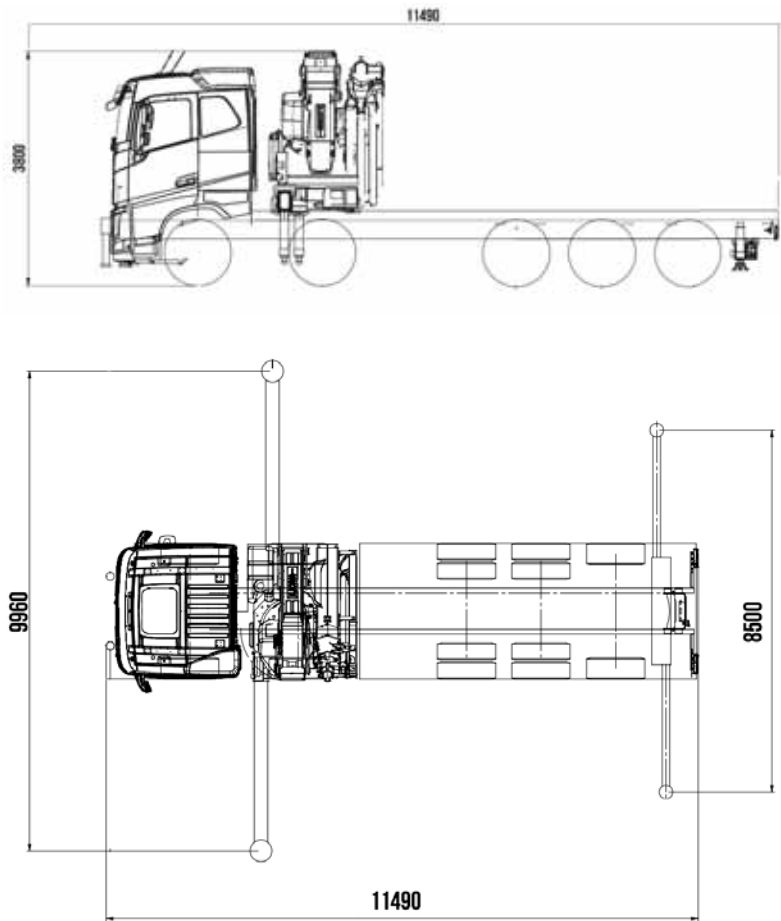

◆ 165 t/m nosturiauto

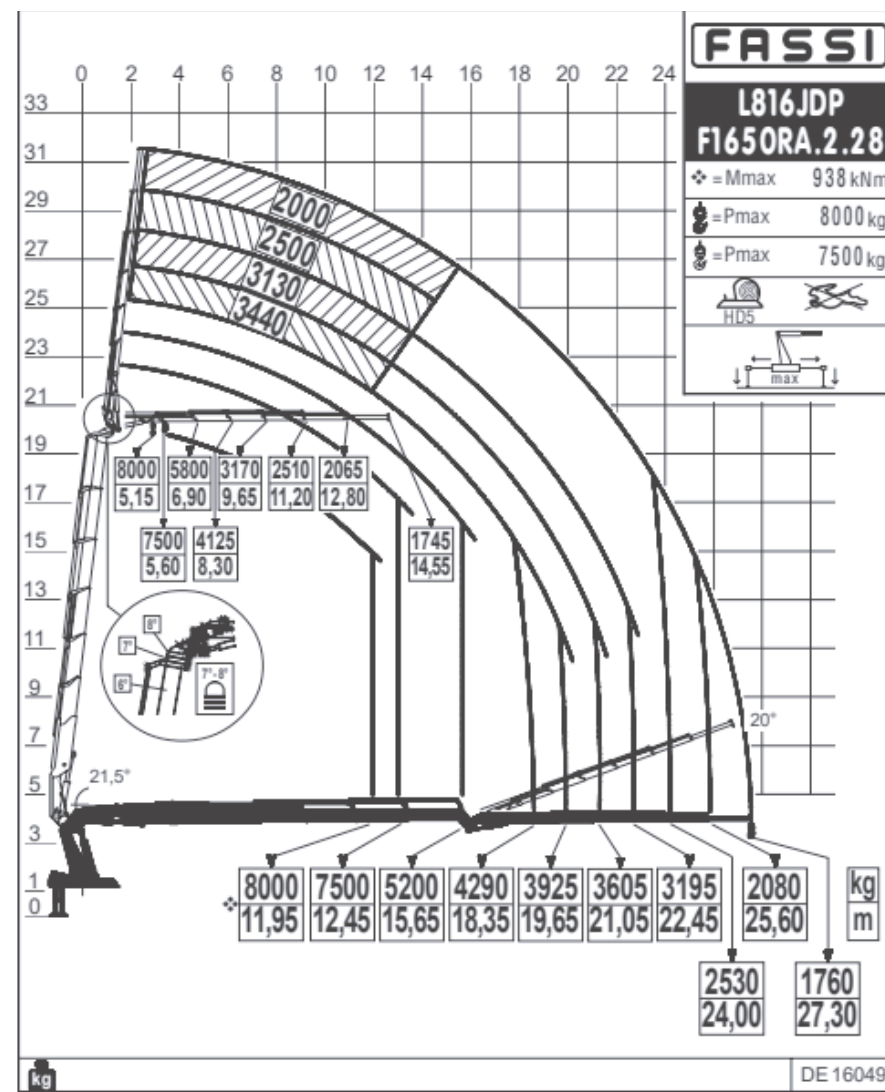
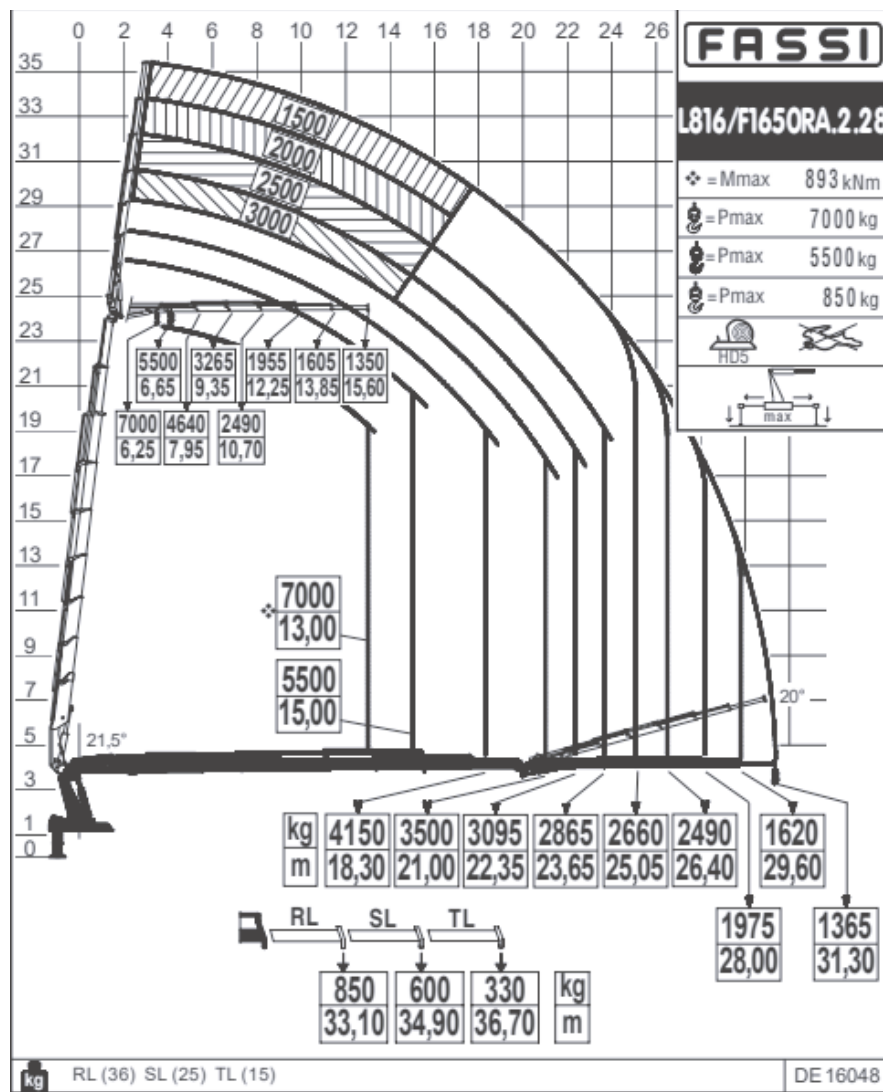

◆ 165 t/m nosturiauto

36400 KG	10000 mM	36,7 m	4000 mM
11690 mM	8500 mM	40 m	2550 mM

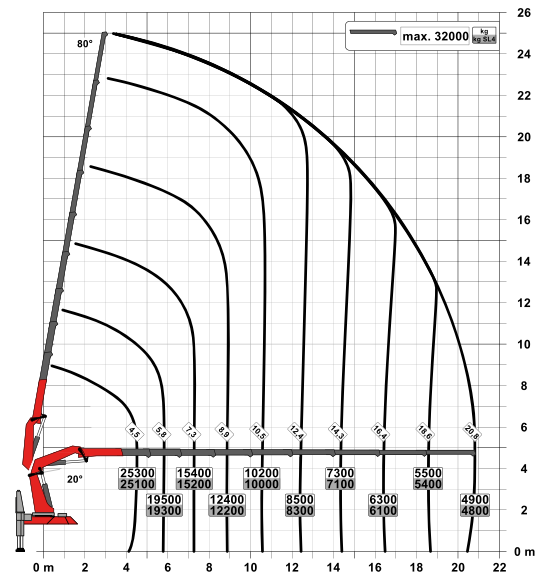
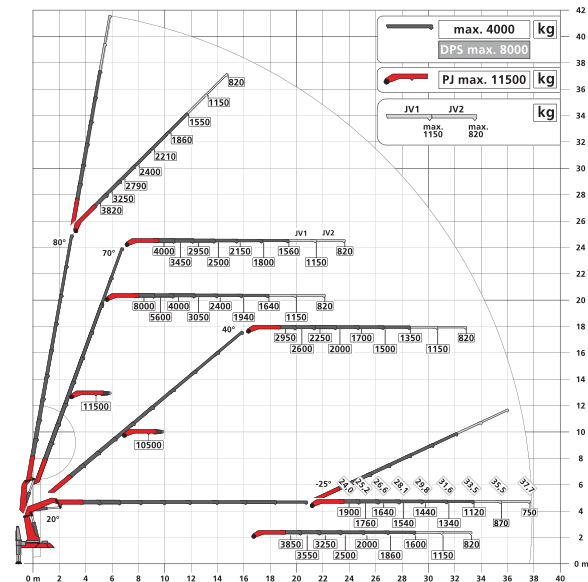
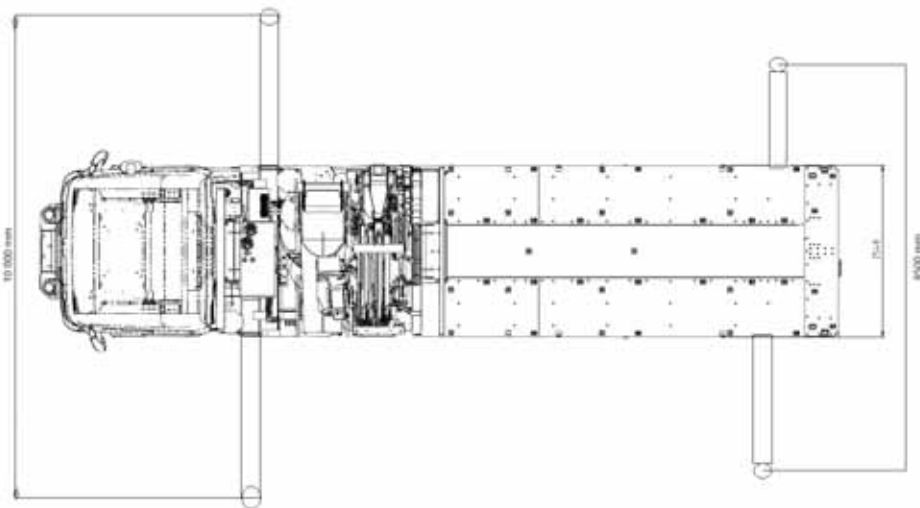
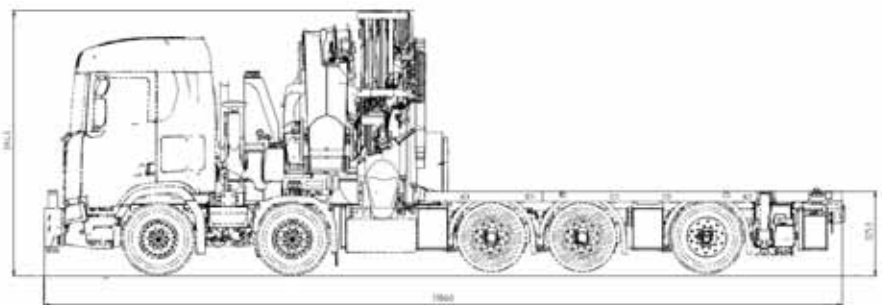



◆ 155 t/m nosturiauto

35300 KG	9980 mM	36,7 m	3800 mm
11480 mM	8500 mM	40 m	2550 mM

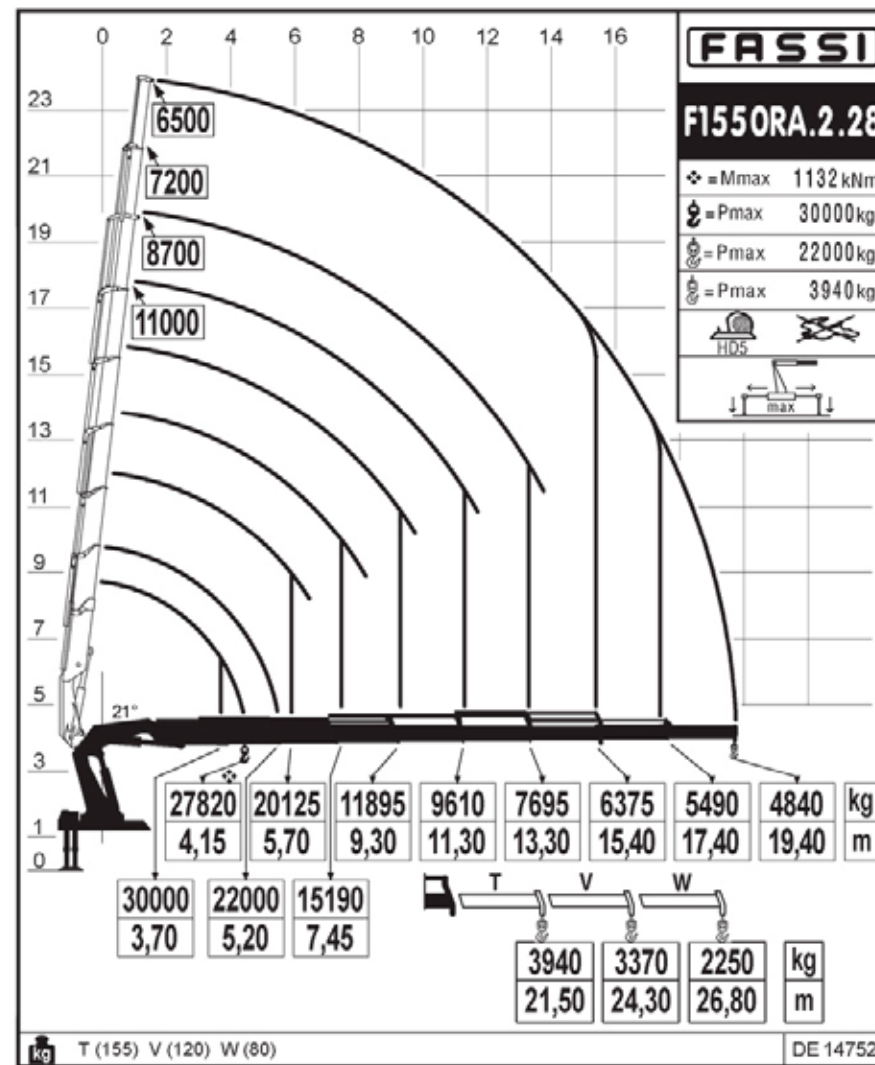
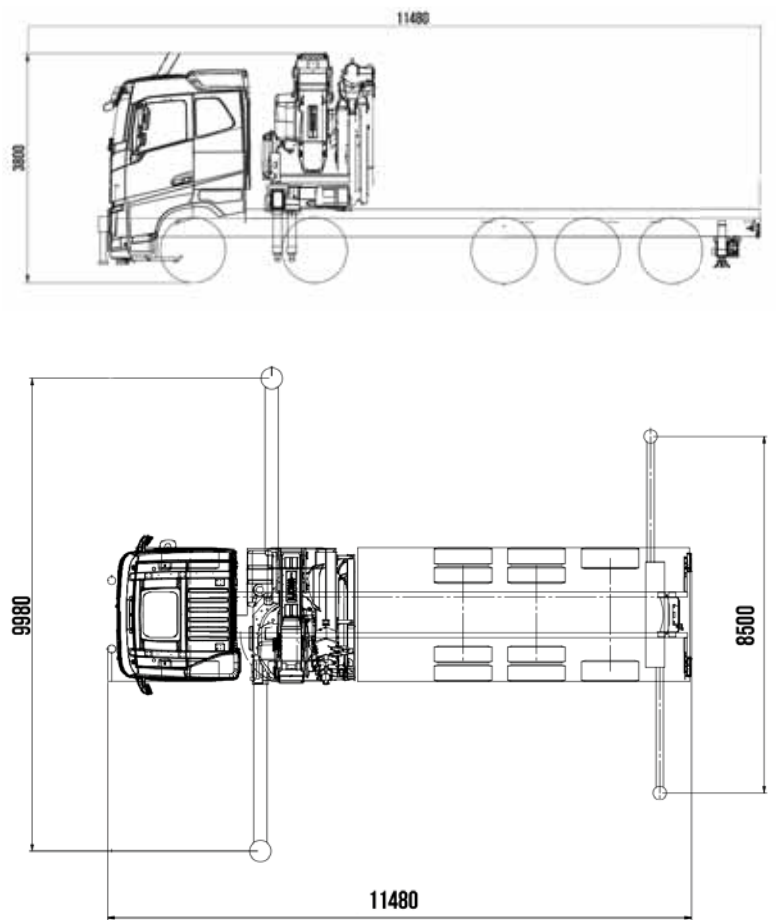

◆ 155 t/m nosturiauto

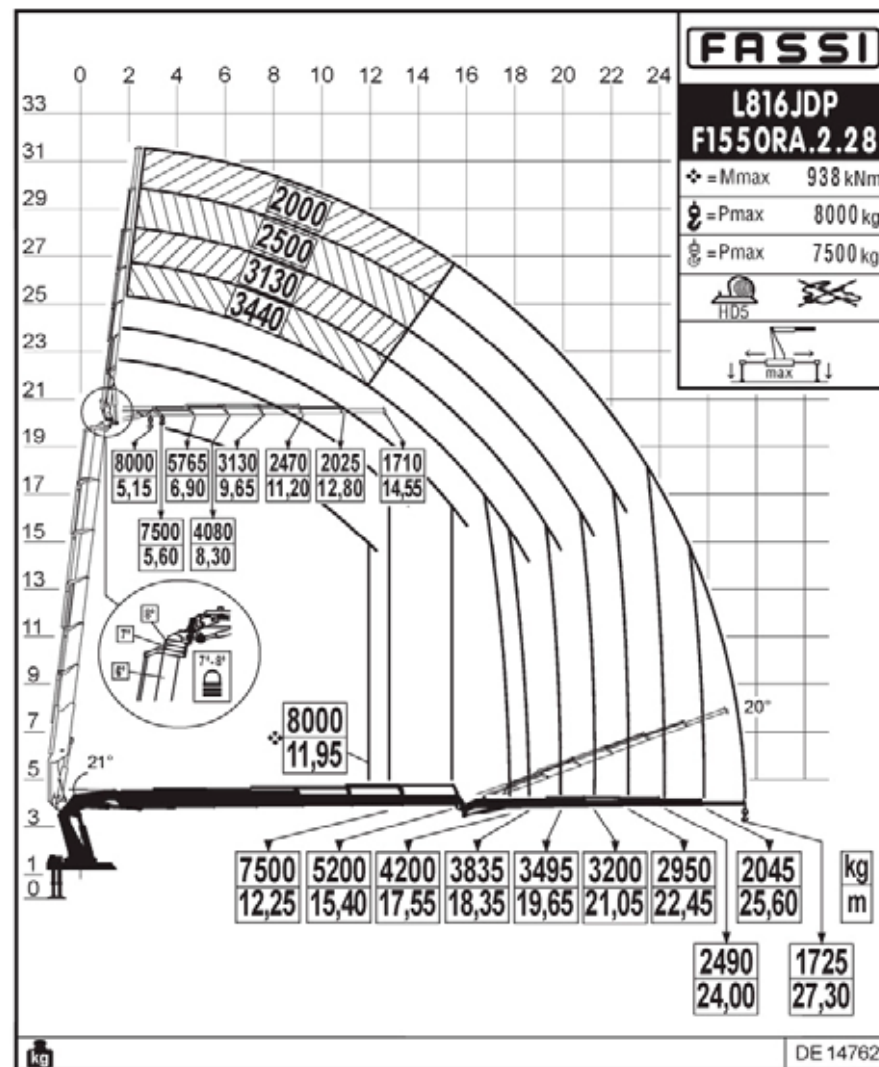
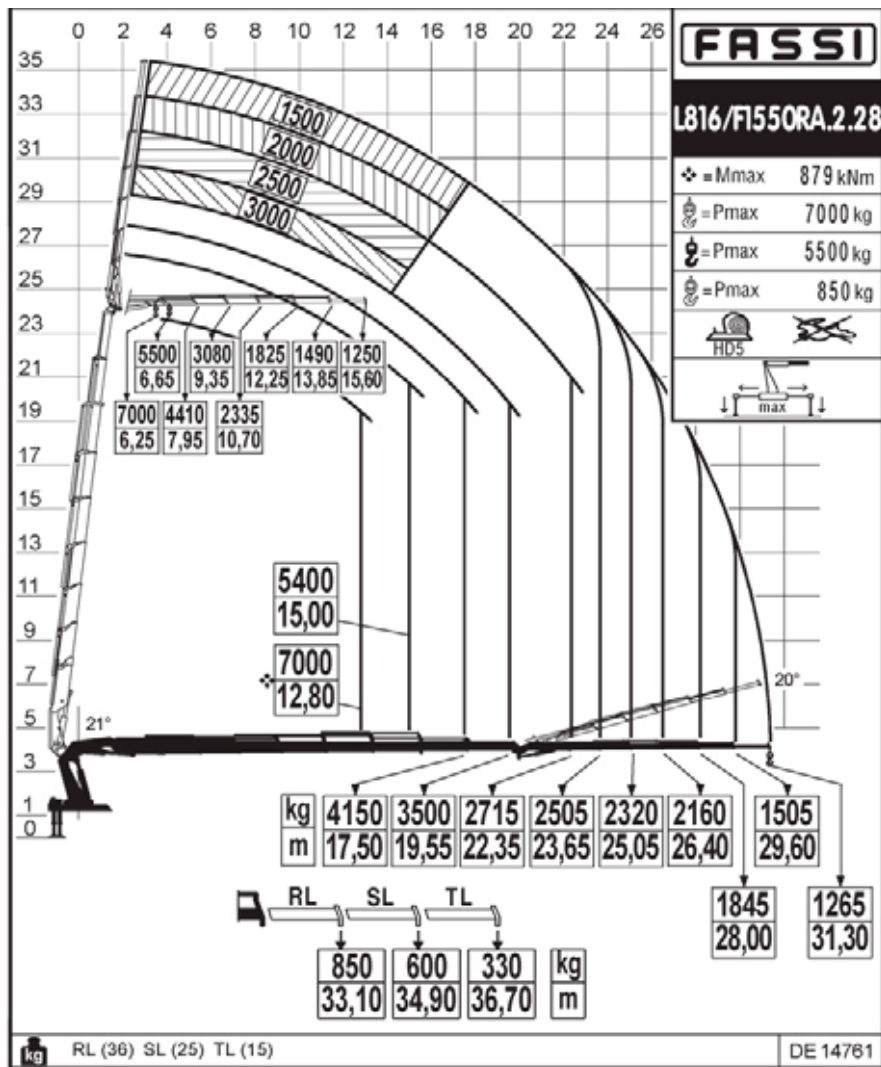

◆ 135 t/m nosturiauto

35000 kg	10000 mm	37 m	4000 mm
11860 mm	7100 mm	40 m	2550 mm

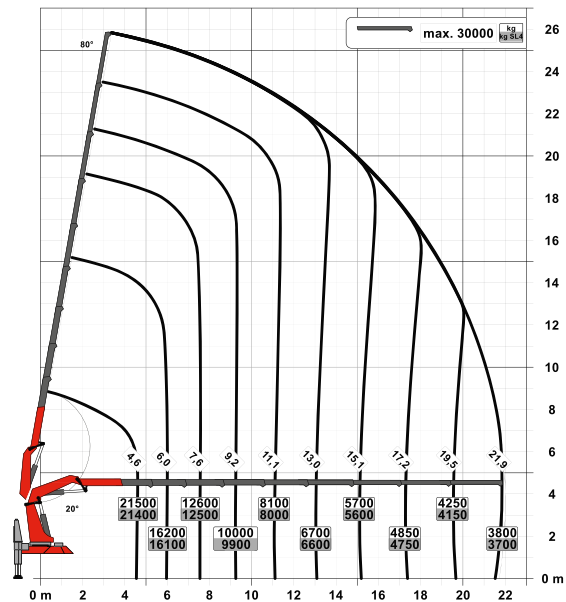
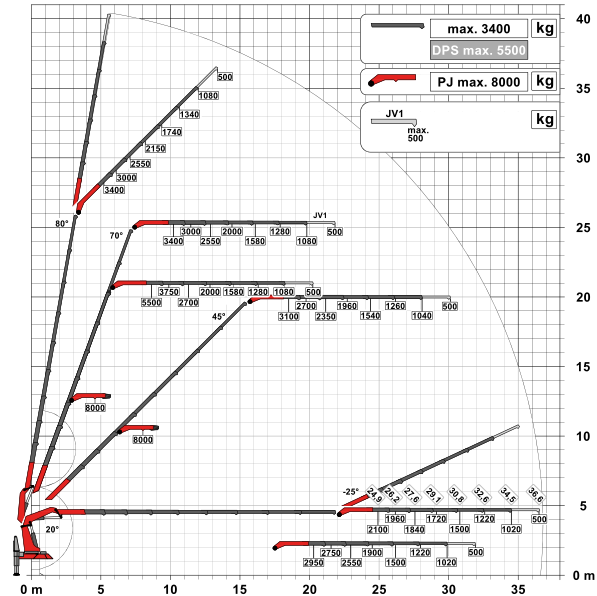
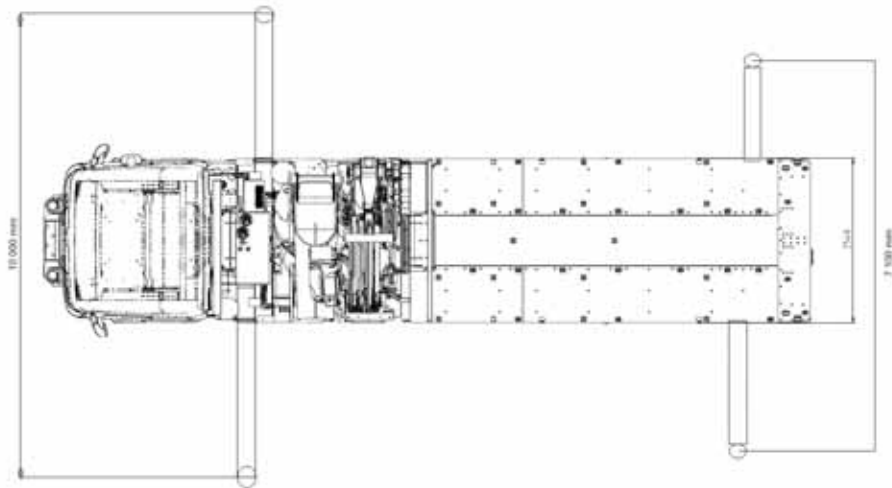
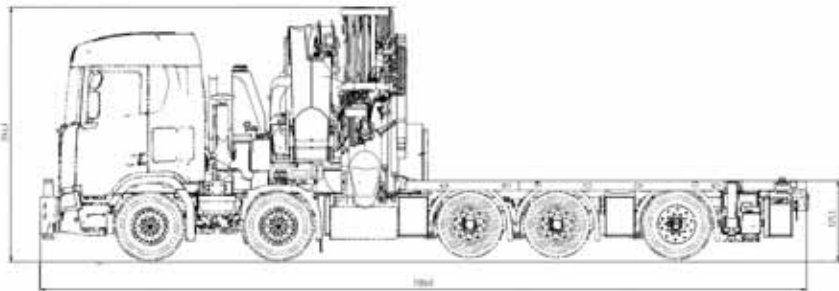

◆ 115 t/m nosturiauto

28000 kg	8840 mm	36,9 m	3755 mm
10913 mm	6670 mm	40 m	2550 mm

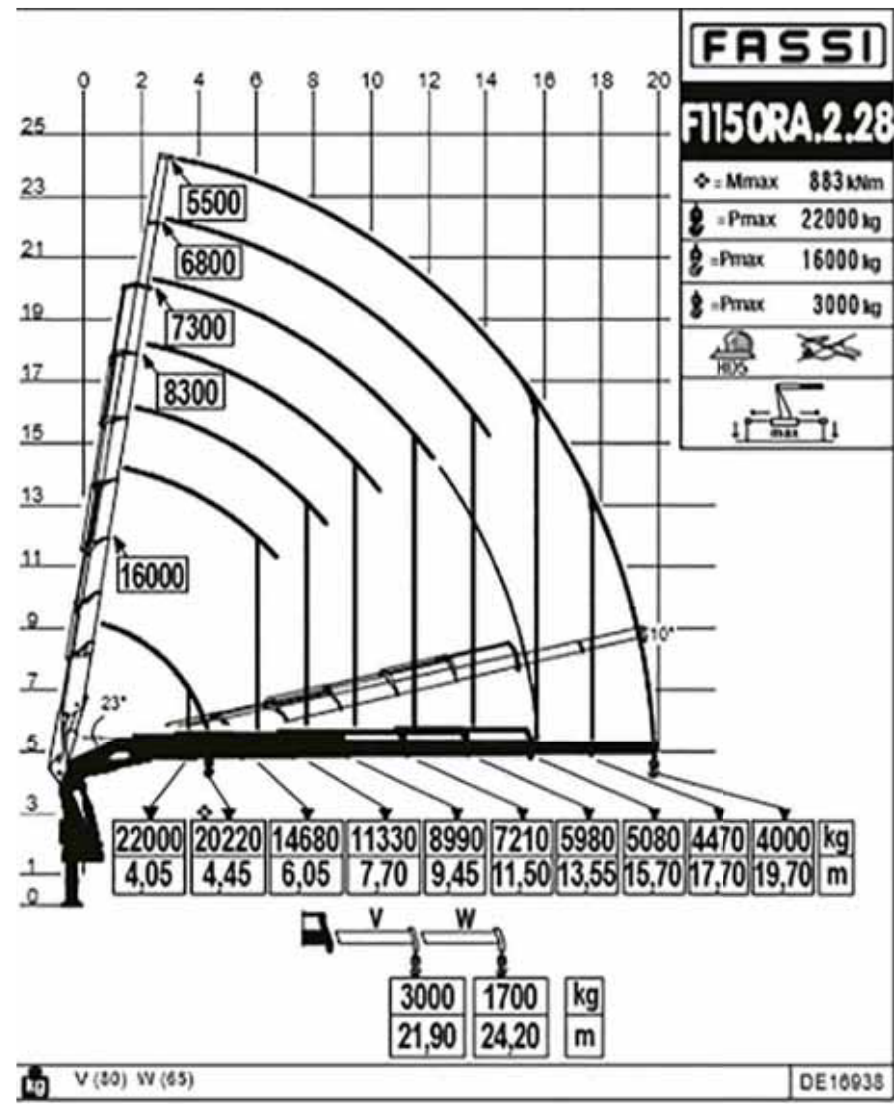
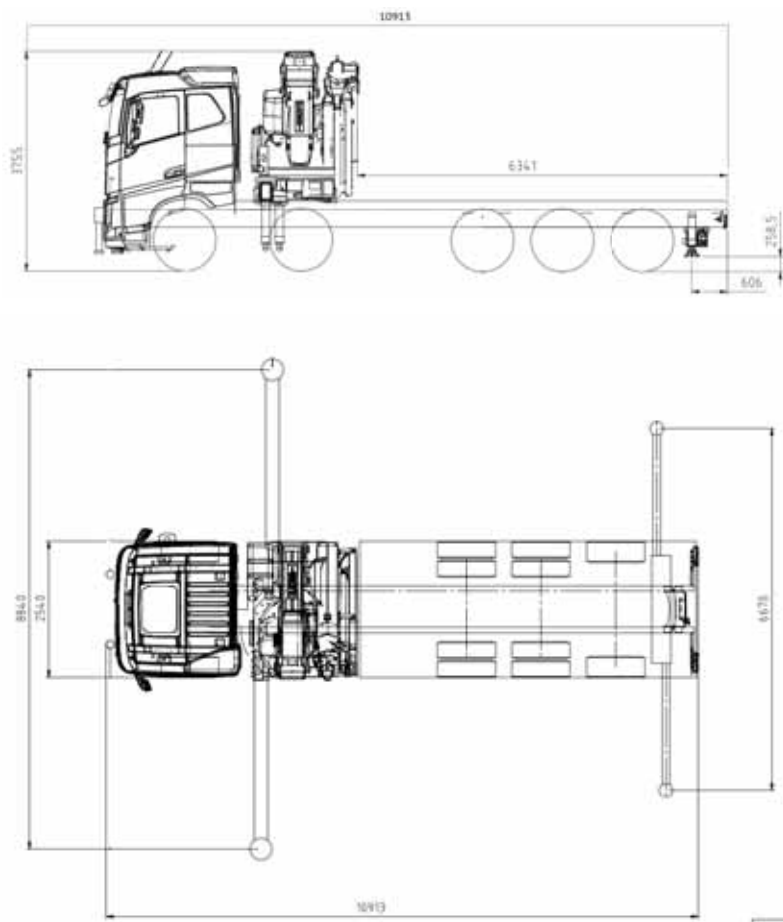

◆ 115 t/m nosturiauto

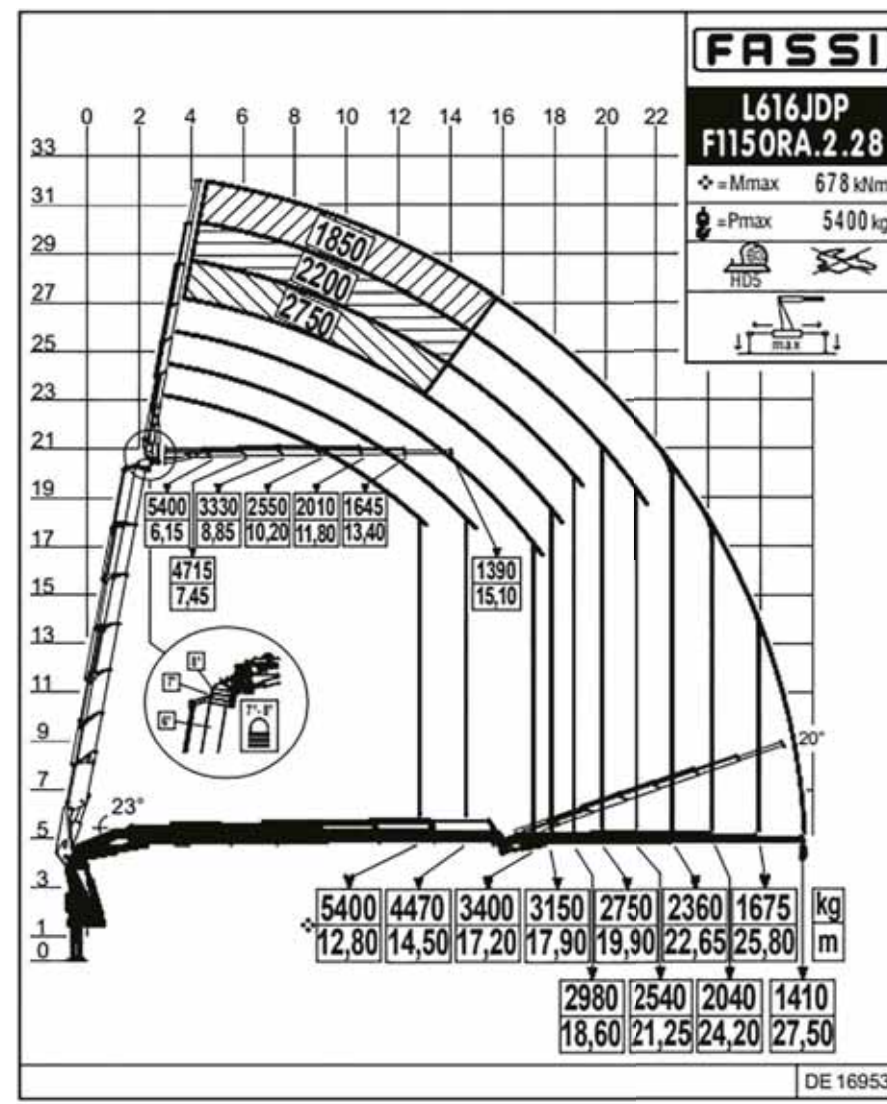
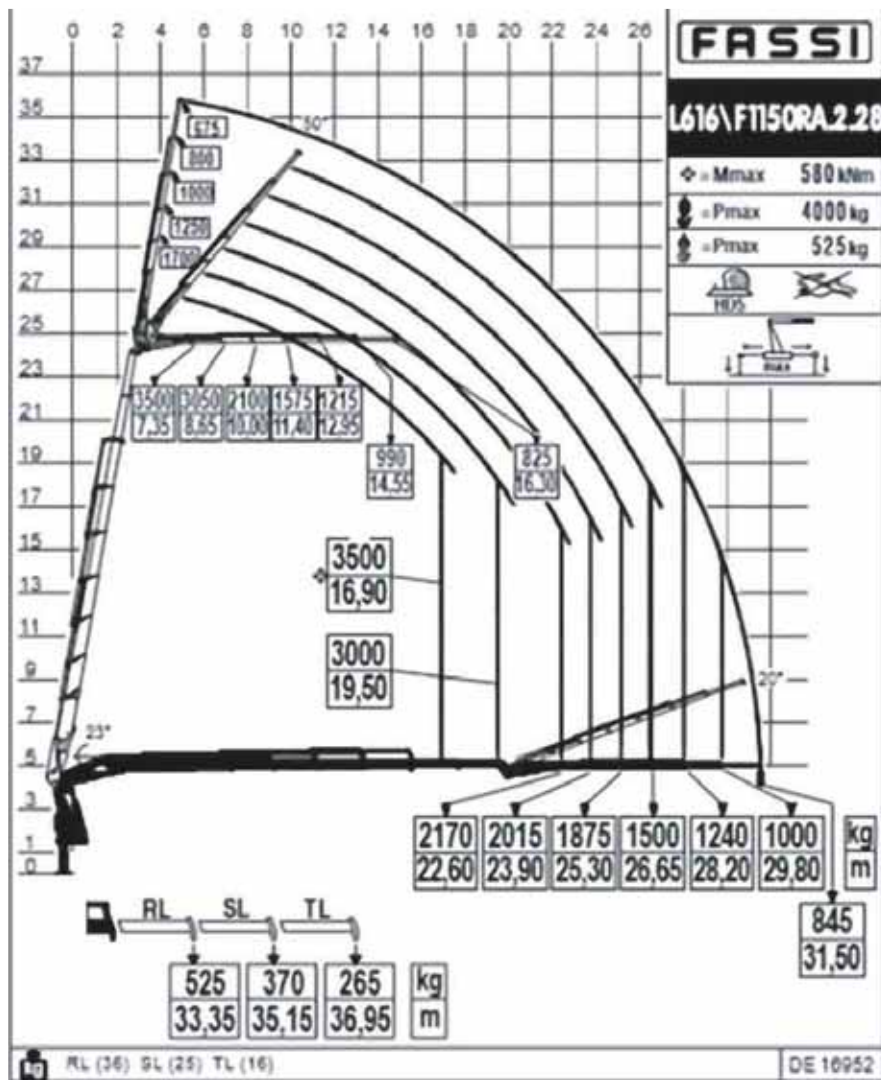

◆ 105 t/m nosturiauto

32500 kg	10000 mm	33,3 m	3679 mm
11859 mm	5900 mm	34 m	2548 mm

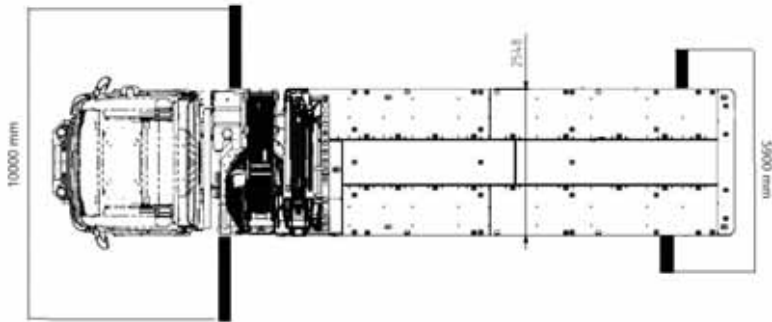
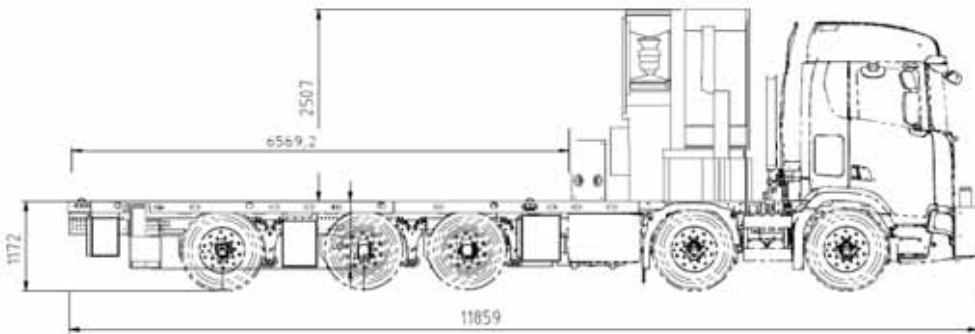

HIAB X-HIPRO 1058 EP-6

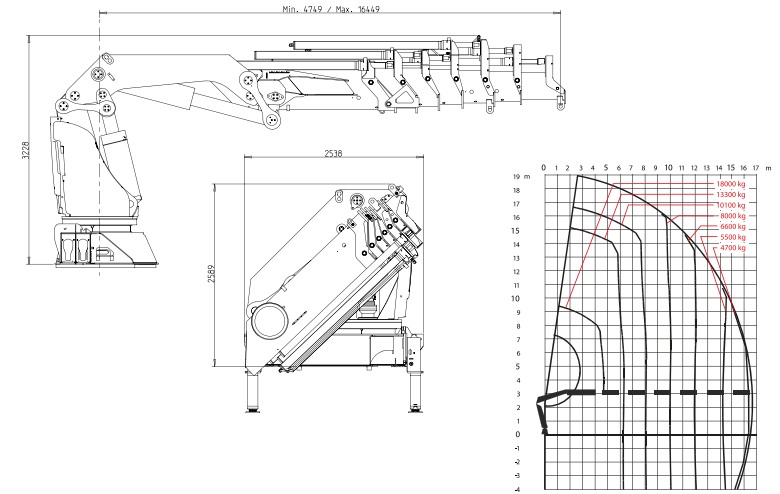

HIAB X-HIPRO 1058 E-8 + JIB 150X-6

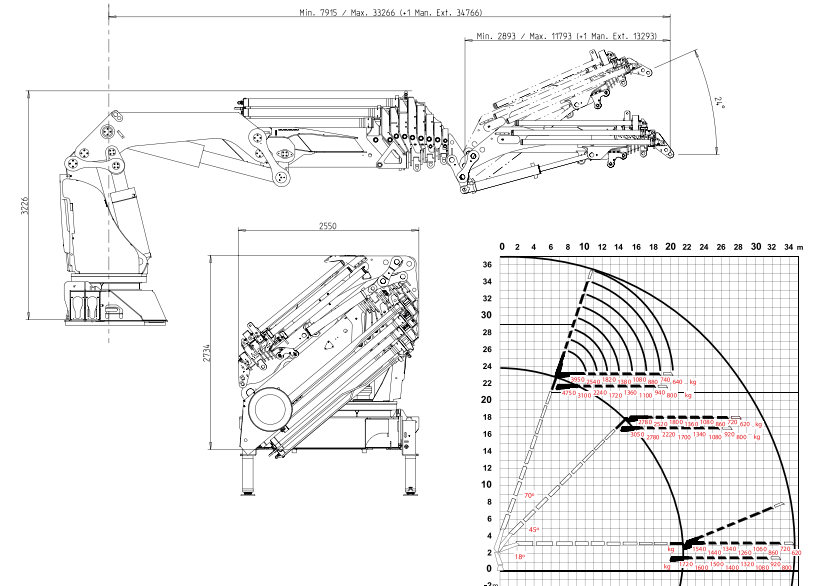

◆ 99 t/m nosturiauto

25300 kg	8500 mm	37 m	3800 mm
10550 mm	5800 mm	40 m	2550 mm

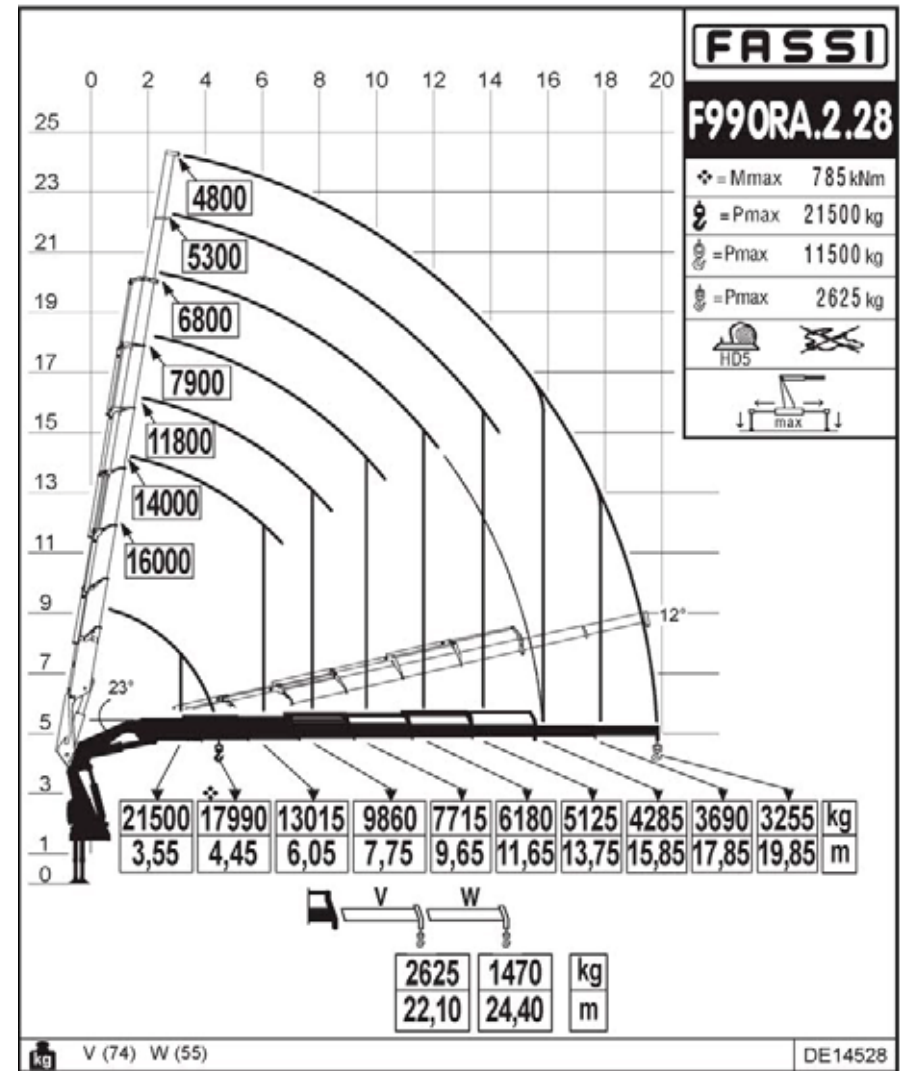
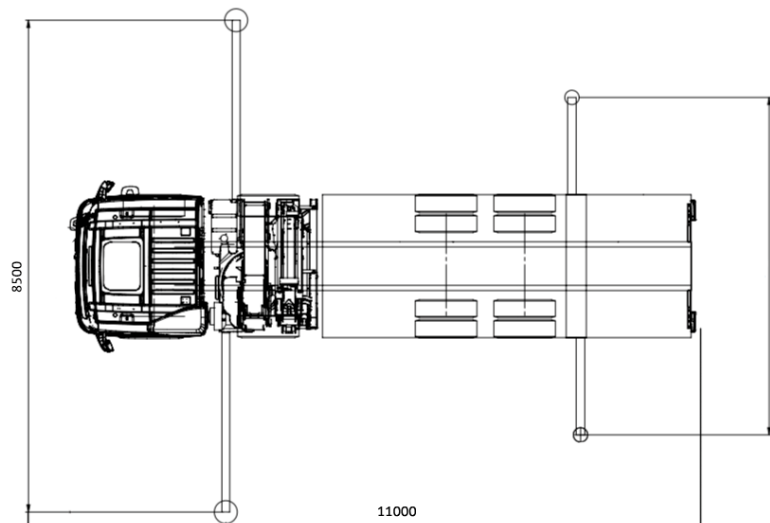
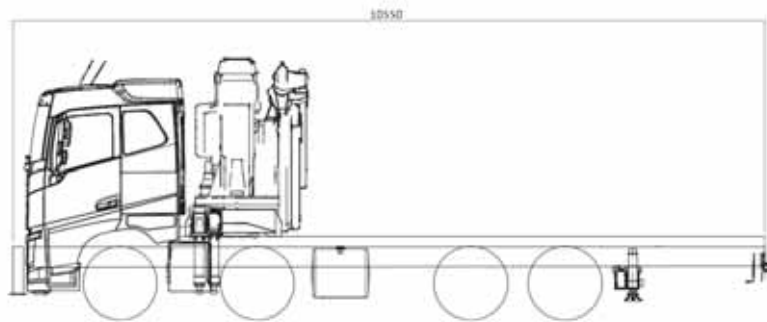

◆ 99 t/m nosturiauto

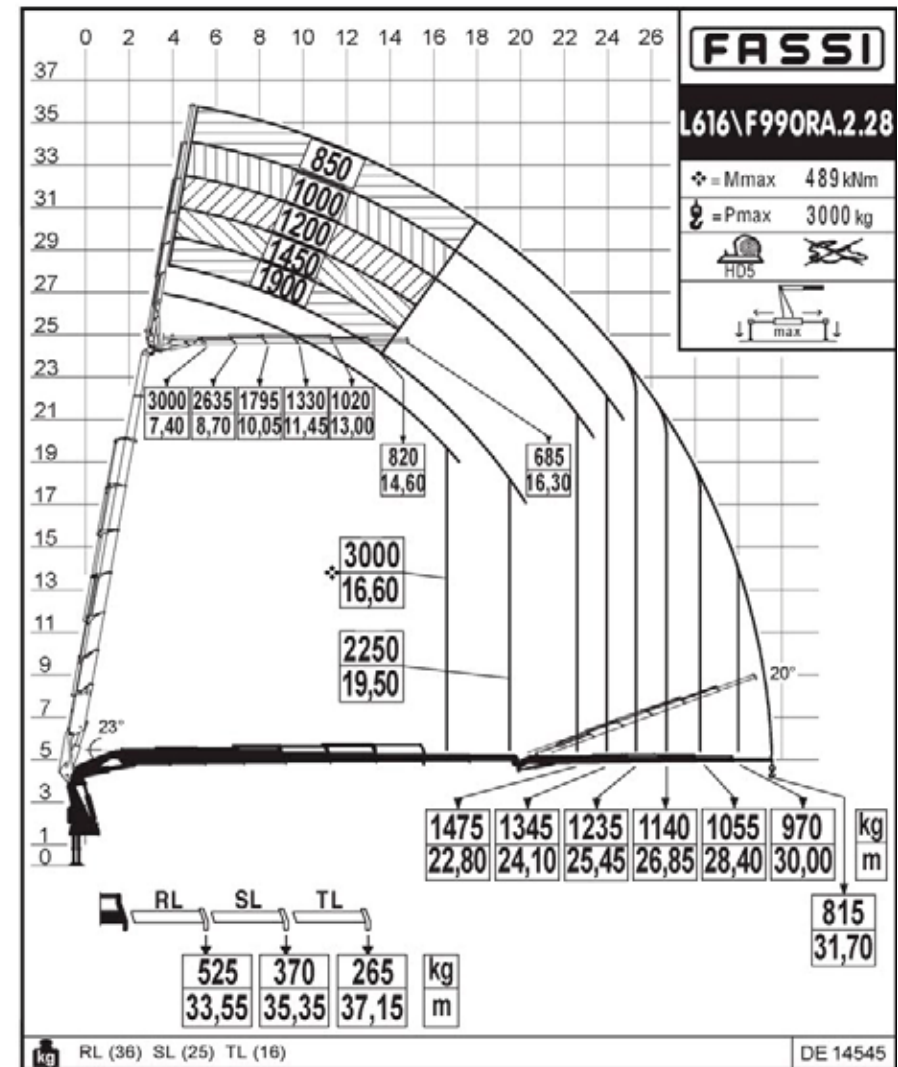
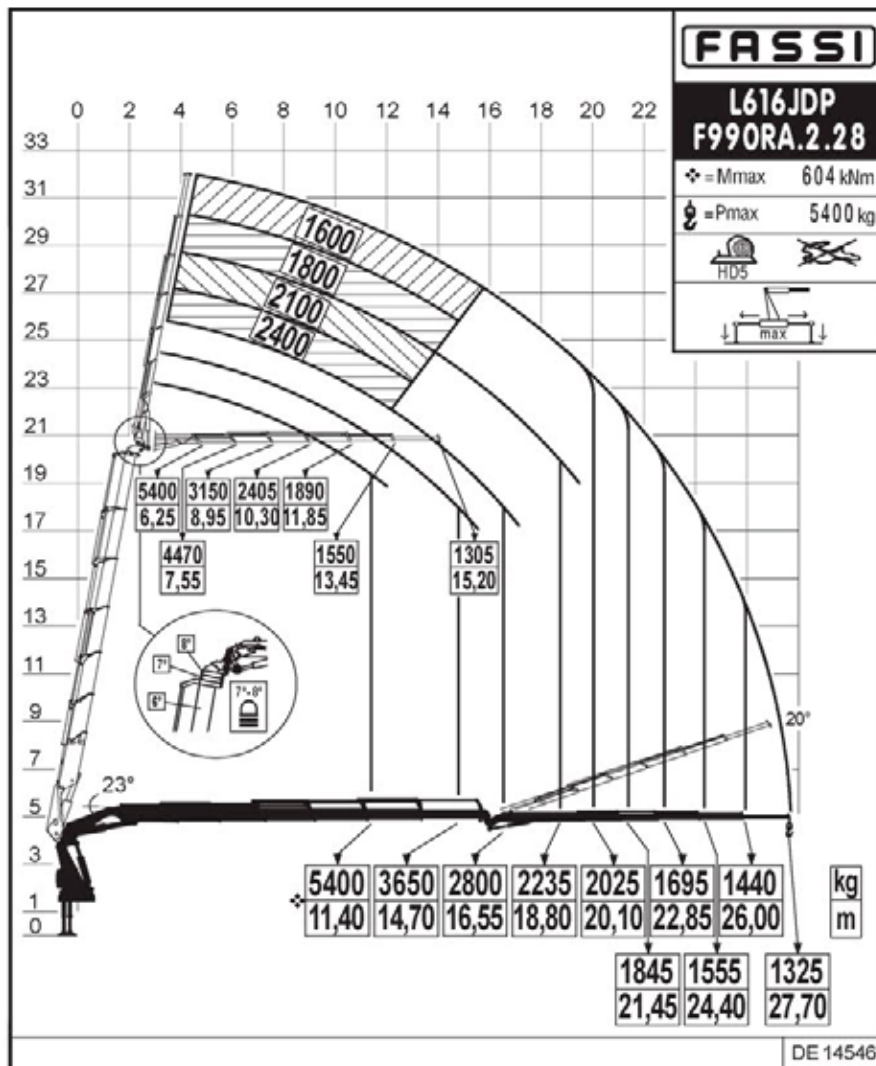



◆ 95 t/m nosturiauto

26850 kg	8500 mm	32 m	3800 mm
11000 mm	5800 mm	36 m	2550 mm

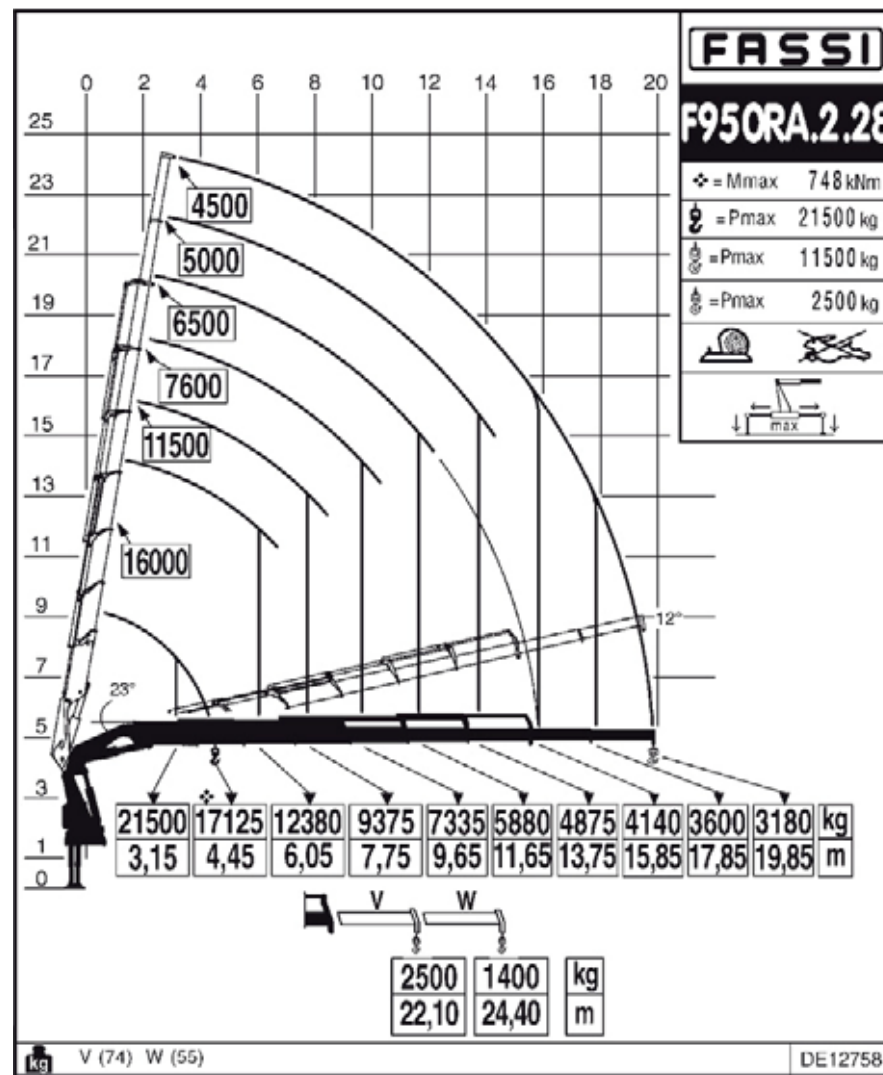
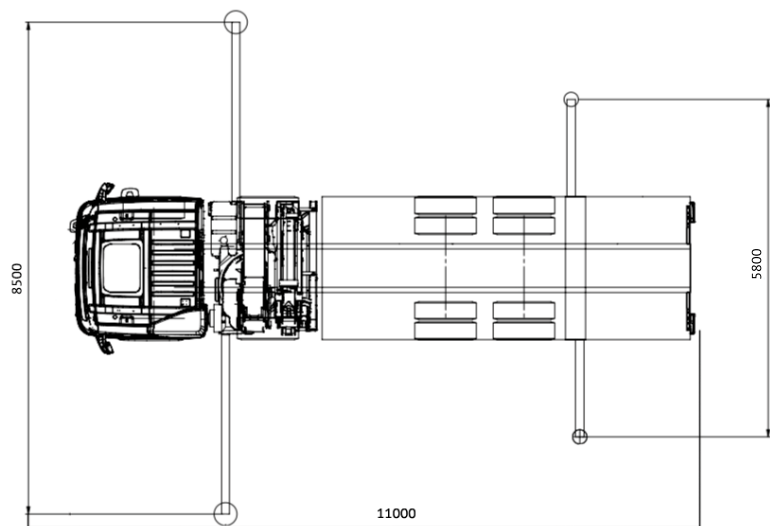
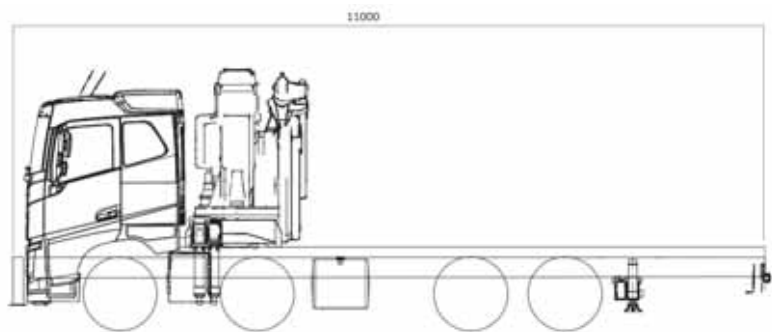

◆ 95 t/m nosturiauto

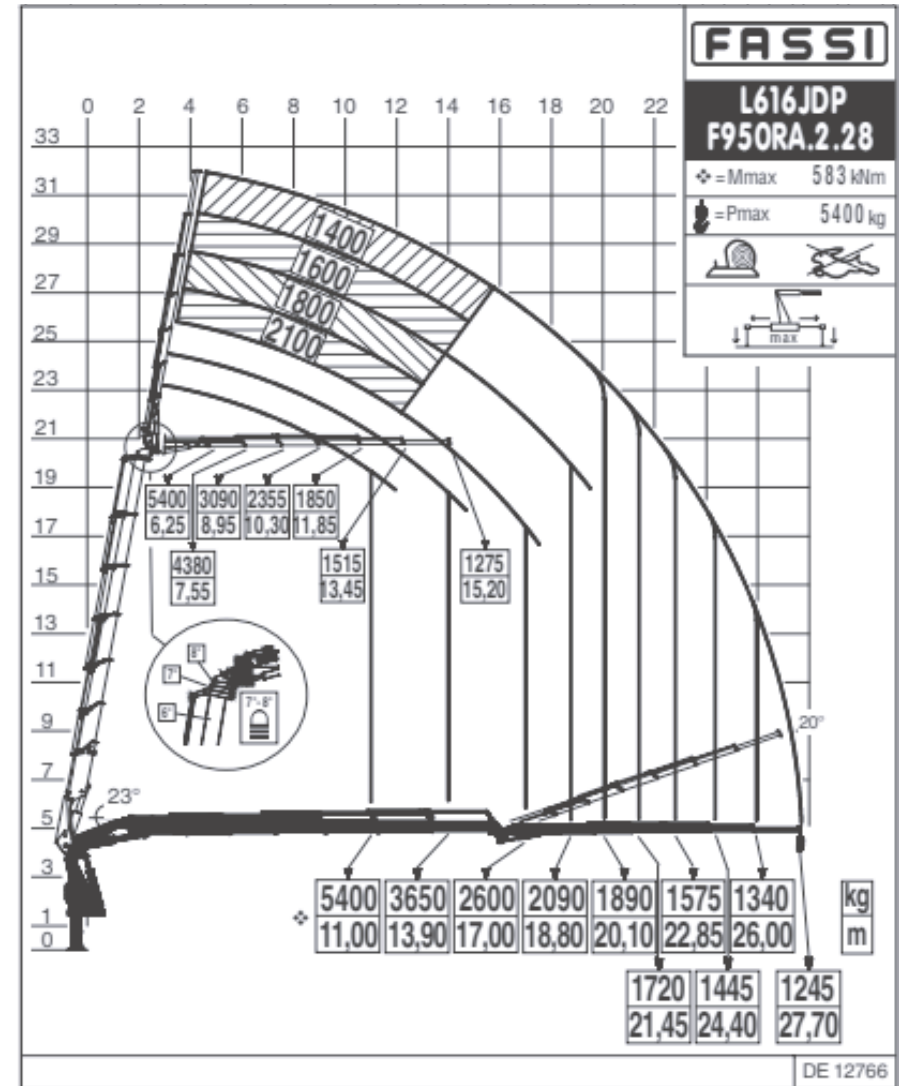
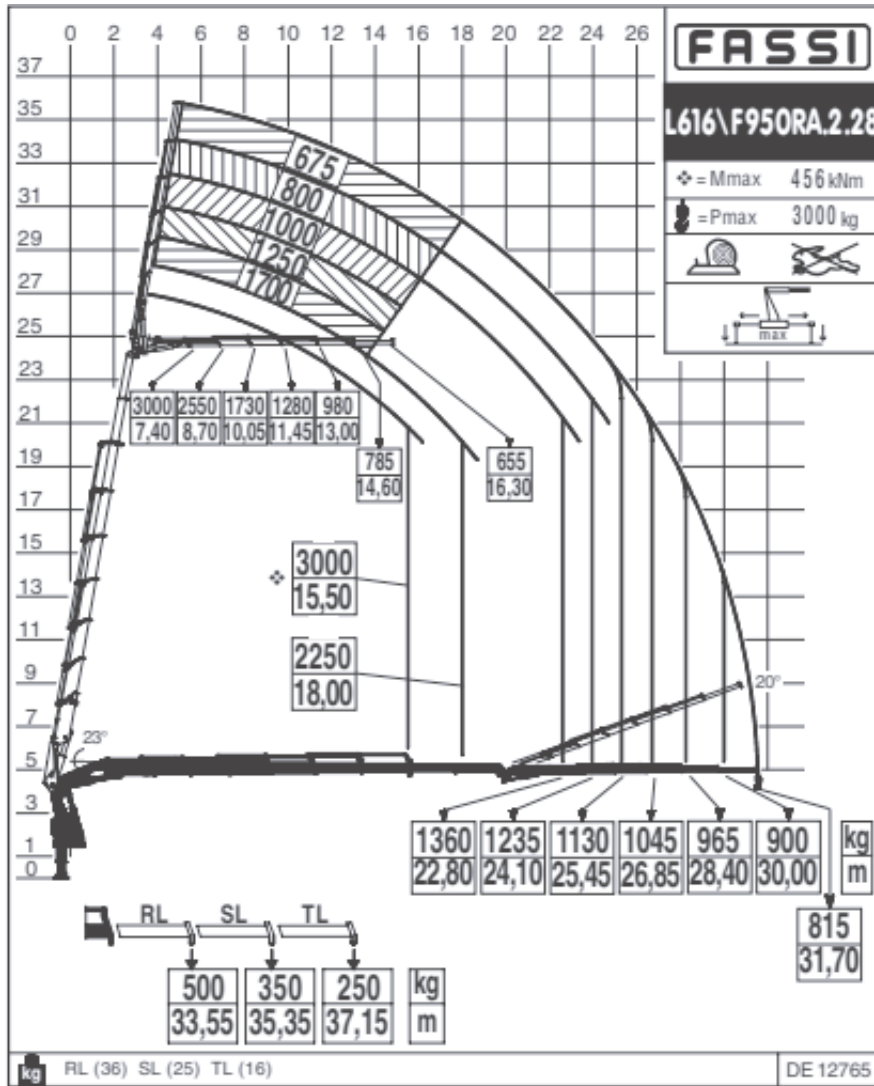



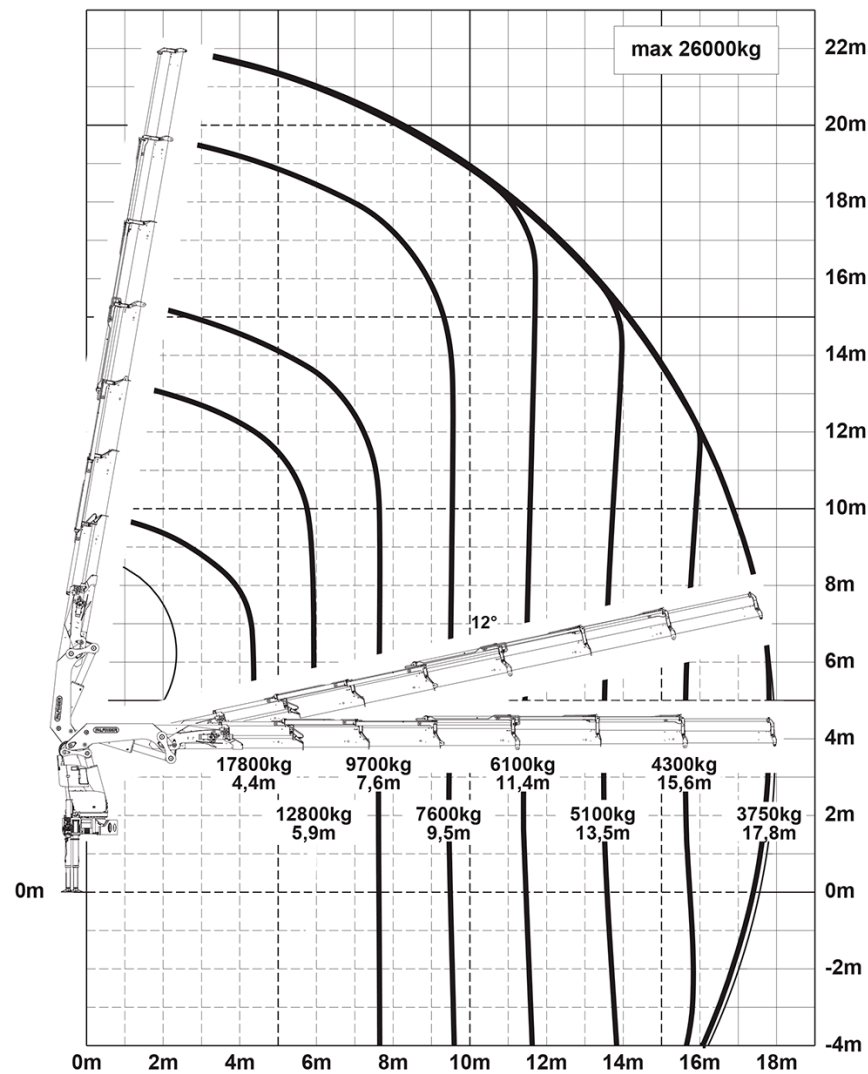
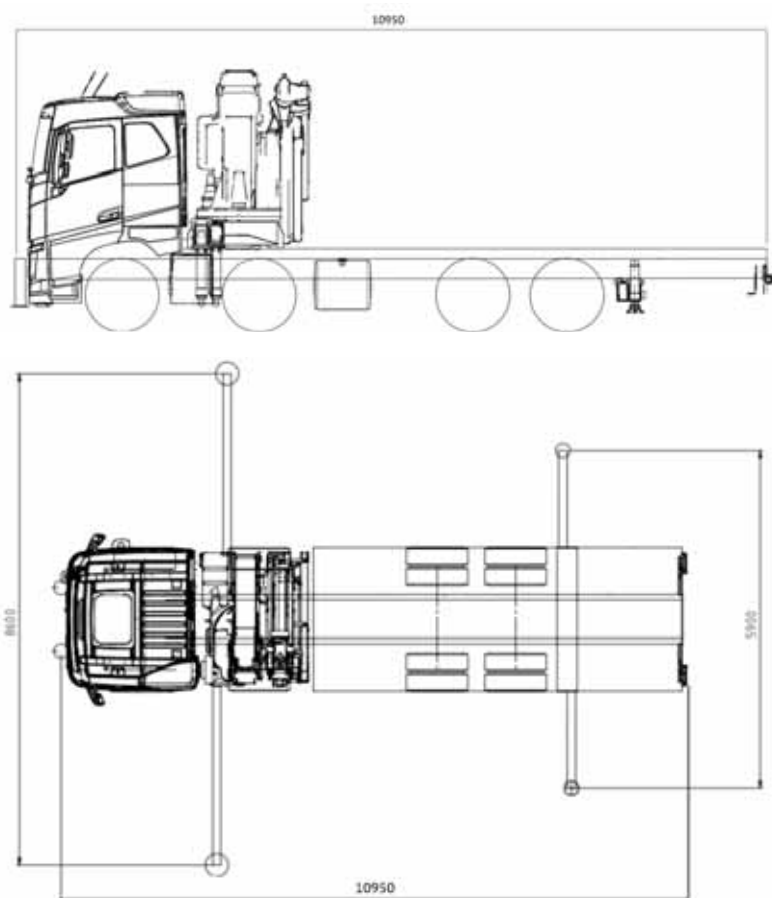
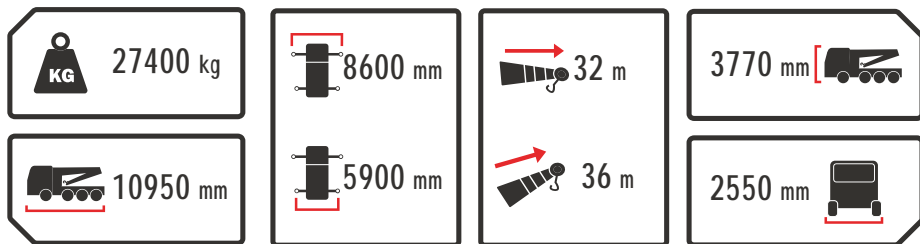

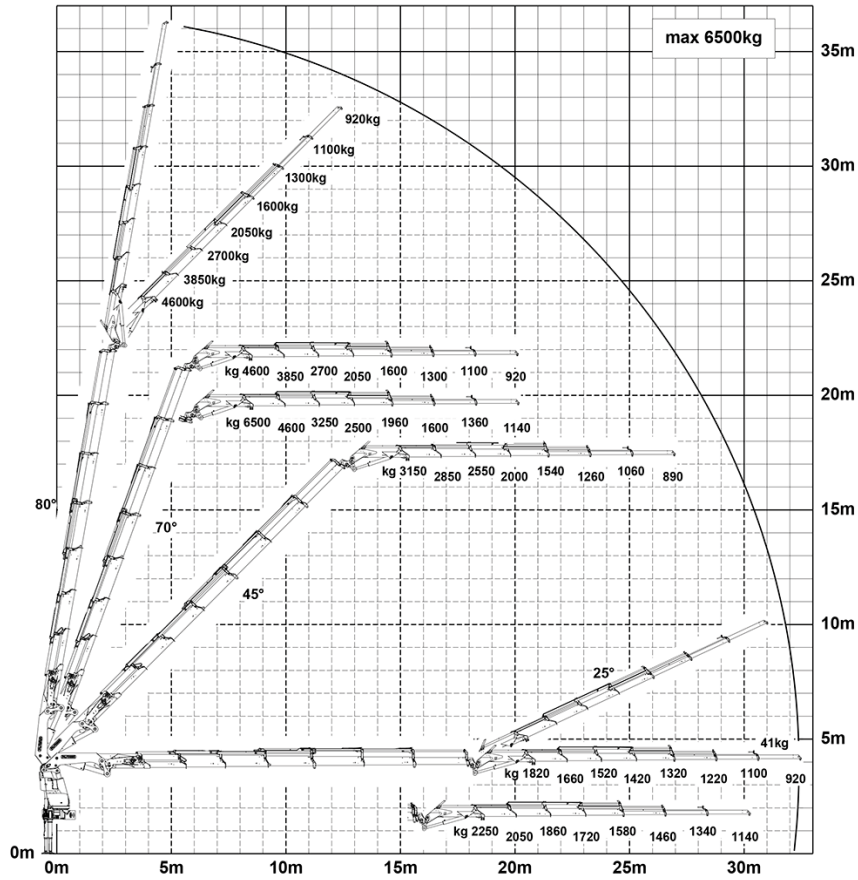

◆ 92 t/m nosturiauto



◆ 92 t/m nosturiauto



◆ 230 tn mobilinosturi

 60000 kg	 8094 mm	4000 mm 
 15600 mm	 111 m	2550 mm 

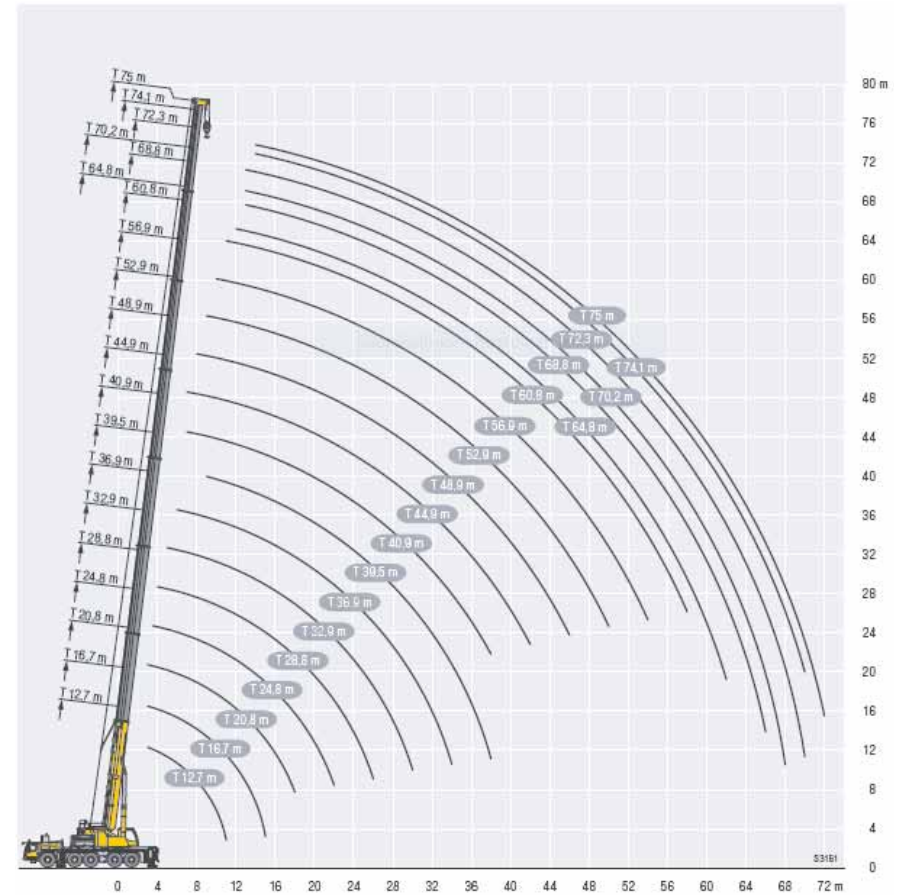
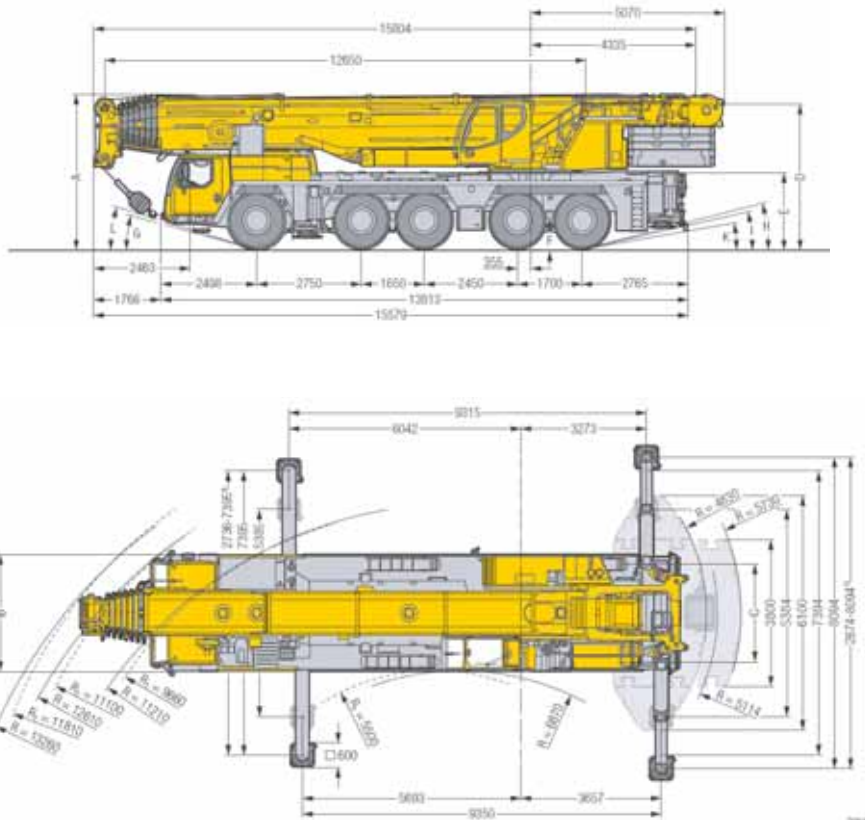

◆ 230 tn mobilinoستوري

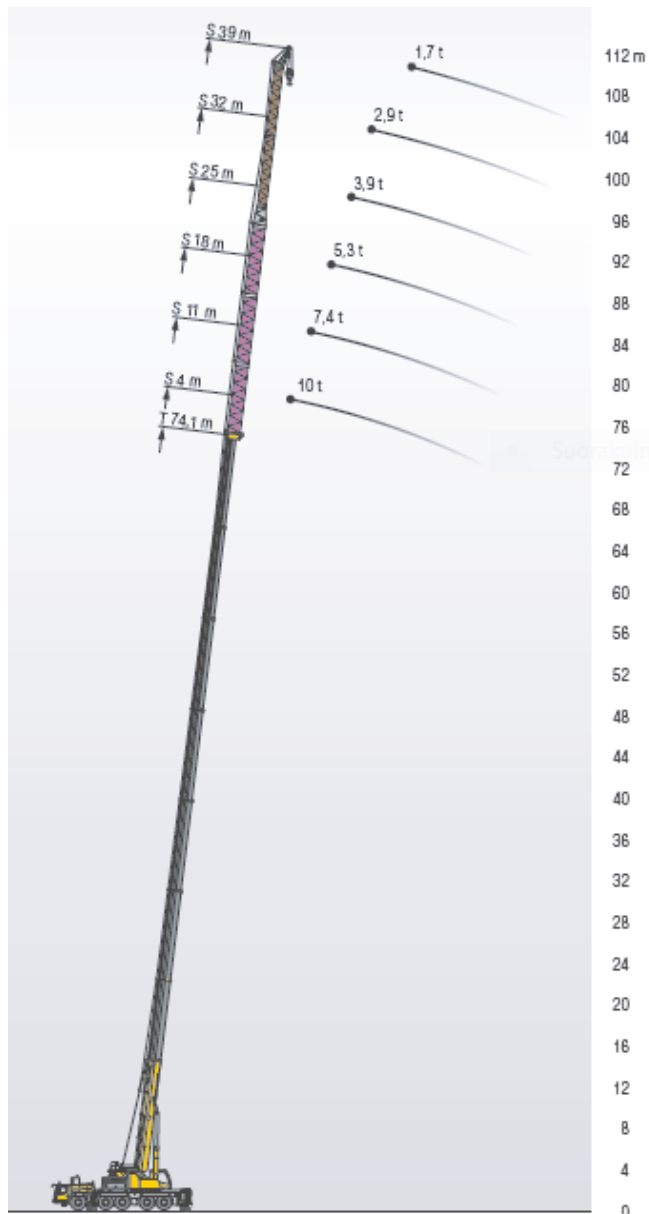

Technical data table for the 230-ton mobile crane, showing weight and height specifications for different configurations.

Legend: 10.7 t, 11.7 m, 10 t, 1.7 m, 0.84 m, 70 t, EN

	12.7 m	16.7 m	20.8 m	24.8 m	28.8 m	32.9 m	36.9 m	40.9 m	44.9 m	
3	230	134	122.1	121.4						3
3.5	148.8	134	123.1	122	121.2					3.5
4	130.5	130.8	124.2	122.8	121.8	105.9				4
4.5	121.8	122.4	121.2	121.4	117.1	106.3				4.5
6	122.8	114.9	114.7	113.2	106.8	102.2				6
6.5	127.5	105.4	101.7	98.4	95.7	92.9	86.9			6.5
7	95.5	95.6	91.3	89.9	86.5	82.9	79.6	75.8		7
8	95.3	91.3	82.3	80.7	75.2	76	72.5	69.8	66.5	8
9	78	73.7	74.7	73.3	71.9	69.5	66.2	64	61.3	9
10	66.4	66.4	68.1	67.1	65.9	64	61	59.4	56.8	10
11		52.6	62.2	61.2	59	56.5	55.1	52.6	46.1	11
12			57.1	57	56.3	54.8	52.6	49	40.9	12
13			32.3	32.2	32.4	30.8	28.8	28.9	26.5	13
14			46.3	45.1	45.6	43.5	40.9	38.5	36.5	14
15			37.1	44.3	45	44.5	44.1	42.7	40.6	15
16				40.9	41.6	41.3	41.5	40.2	38.4	16
18					35.9	35.6	36.2	35.6	34.4	18
20					31.3	31.3	31.6	31.1	30.3	20
22					28.4	28.3	27.9	27.4	26.2	22
24						25.1	24.7	24.1	23.2	24
26							21.8	20.6	20.4	26
28							19.6	19	18.3	28
30								17	17.3	30
32								15.4	16	32
34								14.4	14.5	34
36									13.2	36
38									11.8	38
40										40
42										42





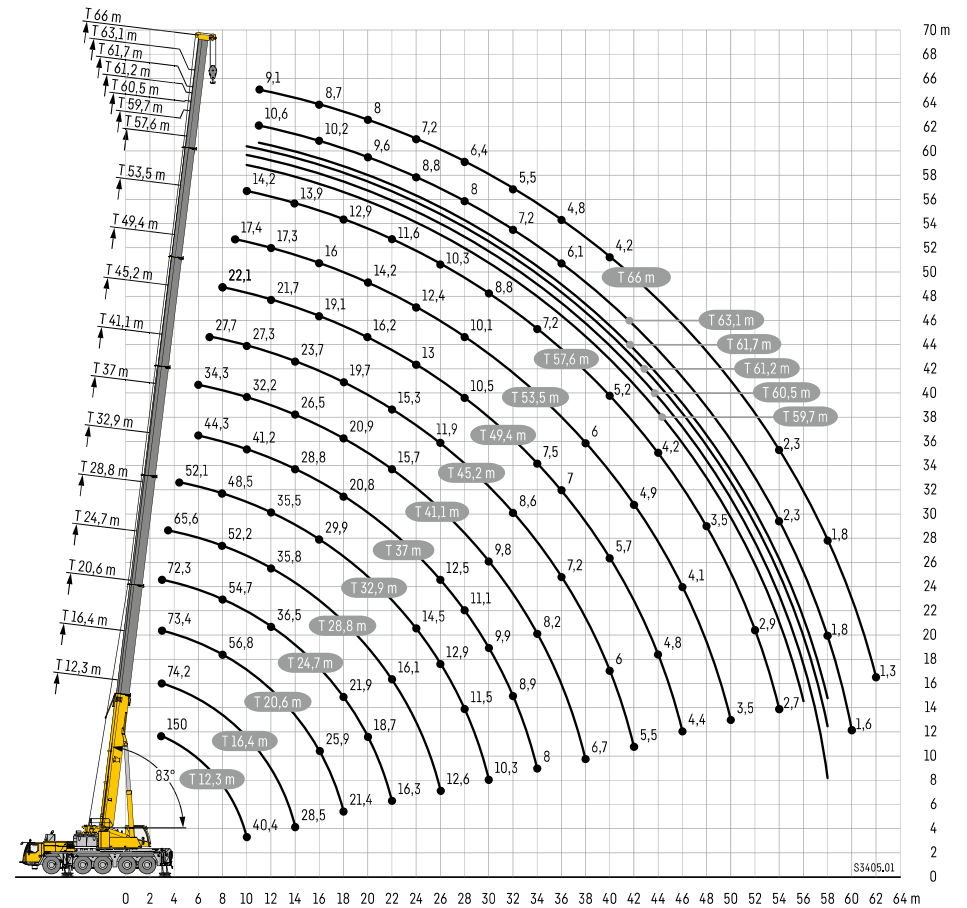
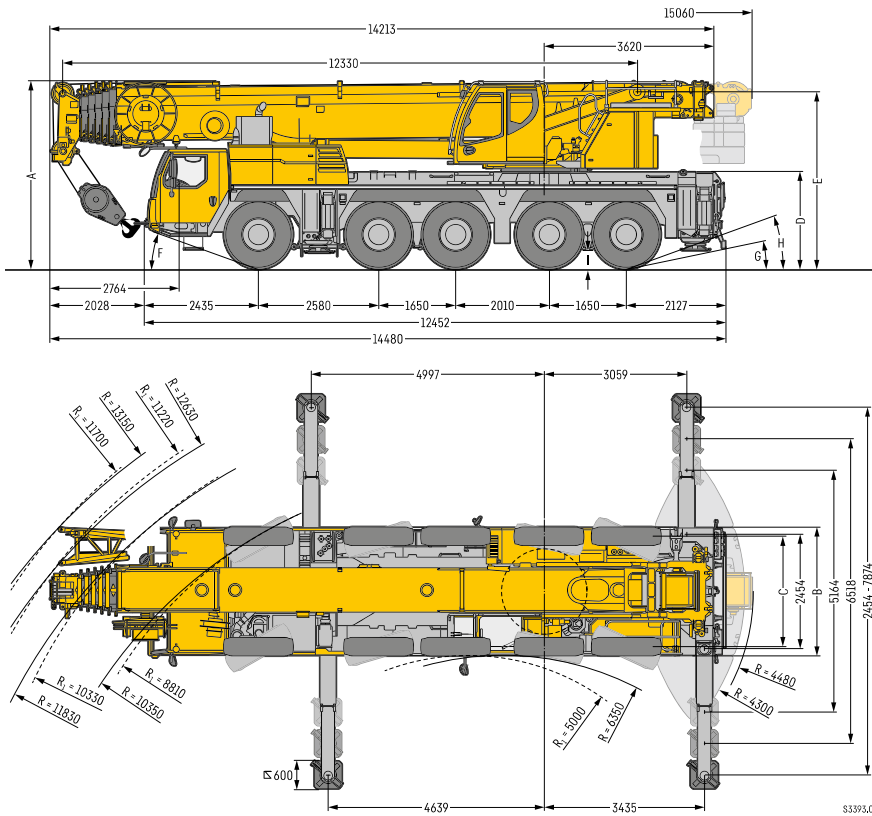

	48.9 m	52.9 m	56.9 m	60.8 m	64.8 m	68.8 m	69.7 m	72.3 m	74.1 m	75 m	
8	39.2										8
9	42.1	34.9									9
10	40	34	28.8								10
11	38	32.8	29.3								11
12	36.1	31.9	27.4	23.8	19.7						12
13	34.3	30.8	26.4	22.8	19.8	16.4	15.3	12.5			13
14	32.6	29.7	25.5	22.1	19.2	16.2	15.6	12.7	12	11.7	14
15	31.1	28.4	24.6	21.4	18.8	15.9	15.4	12.6	11.9	11.6	15
16	29.7	27.2	23.7	20.7	18.2	15.6	15.1	12.5	11.7	11.4	16
18	27.2	25.1	22.1	19.4	17.2	14.9	14.4	11.9	11.3	11	18
20	25.3	23.2	20.7	18.2	16.2	14.3	13.8	11.4	10.8	10.6	20
22	23.5	21.5	19.4	17.1	15.3	13.6	13.2	10.9	10.4	10.2	22
24	21.7	19.9	18.1	16.1	14.5	12.9	12.6	10.4	9.9	9.7	24
26	19.9	18.5	16.9	15.1	13.7	12.3	12	9.9	9.4	9.3	26
28	18.3	17	15.7	14.1	12.9	11.6	11.3	9.5	9.1	8.8	28
30	16.7	15.7	14.6	13.3	12.1	10.9	10.7	9	8.4	8.2	30
32	14.9	14.3	13.3	12.4	11.4	10.3	10.1	8.6	7.9	7.8	32
34	13.4	13.1	12	11.6	10.7	9.7	9.6	8.2	7.5	7.4	34
36	12.1	12.2	11.8	10.9	10.1	9.3	9	7.9	7.1	7	36
38	11.4	11.4	10.6	10.2	9.5	8.6	8.5	7.5	6.7	6.6	38
40	10.7	10.4	9.7	9.6	9	8.2	8	7.2	6.3	6.2	40
42	9.5	9.4	8.9	8.8	8.2	7.7	7.6	6.9	5.9	5.9	42
44	8	8.6	8.2	8.1	7.5	7.3	7.2	6.6	5.6	5.4	44
46	7.6	8	7.5	7.4	6.9	6.5	6.5	5.8	5.3	5	46
48		7.7	7.2	7.1	6.9	6.5	6.5	6	5	4.7	48
50		6.6	6.3	6.6	6.3	6	6.1	5.7	4.7	4.4	50
52			6.2	6.3	6.2	5.7	5.4	5.3	4.4	4.1	52
54			5.6	5.8	5.3	5.3	4.9	5	4.2	3.8	54
56				5.3	4.9	4.4	4.4	4.1	4	3.6	56
58					4.8	4.4	4.1	4.2	3.8	3.4	58
60						4.5	4.2	3.9	3.6	3.2	60
62							4.4	4.2	3.8	3.4	62
64								3.7	3.4	3	64
66									3.5	3.1	66
68										2.7	68
70											70
72											72

◆ 150 tn mobilinosturi

60000 kg	8094 mm	4000 mm
15600 mm	111 m	2550 mm



◆ 95 tn mobilinosturi

 60000 kg	 7000 mm	4000 mm 
 14000 mm	 82 m	2750 mm 

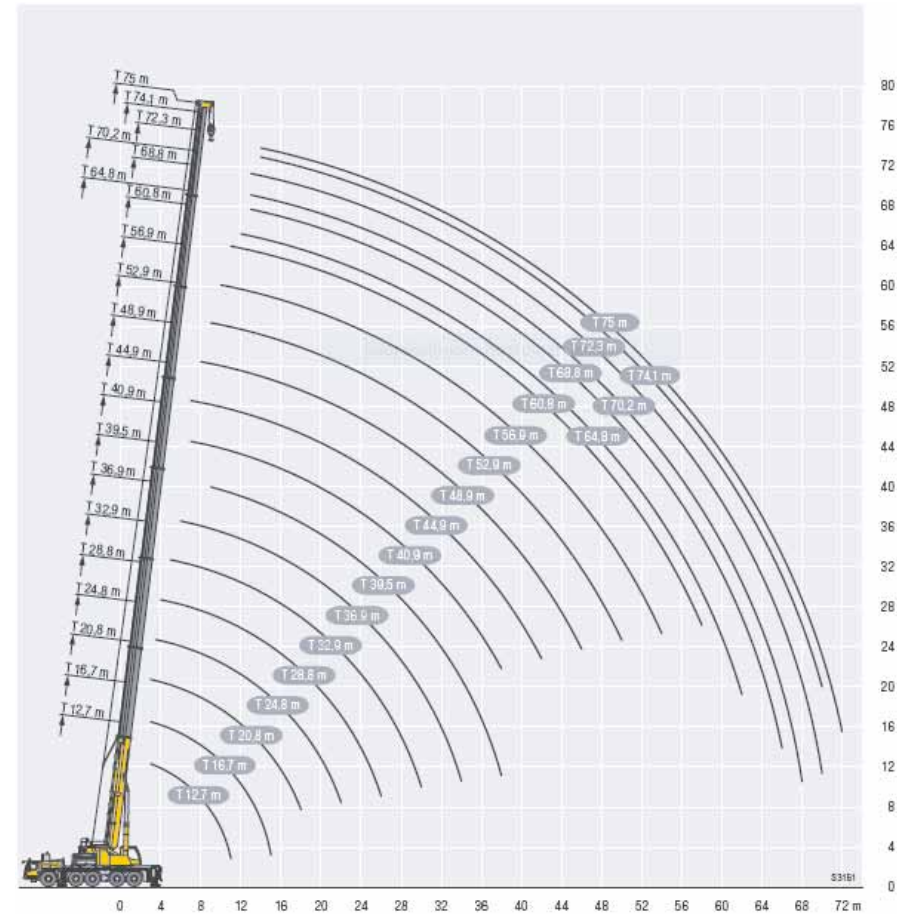
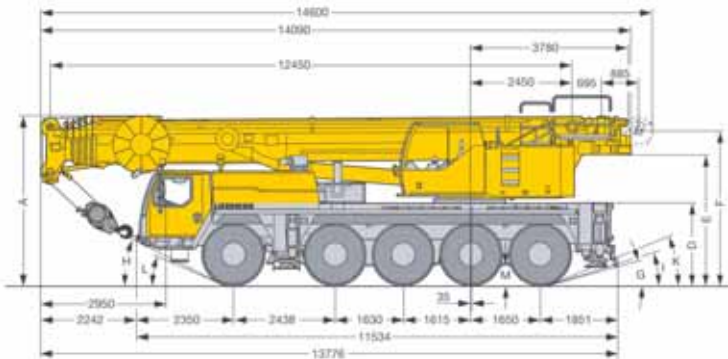
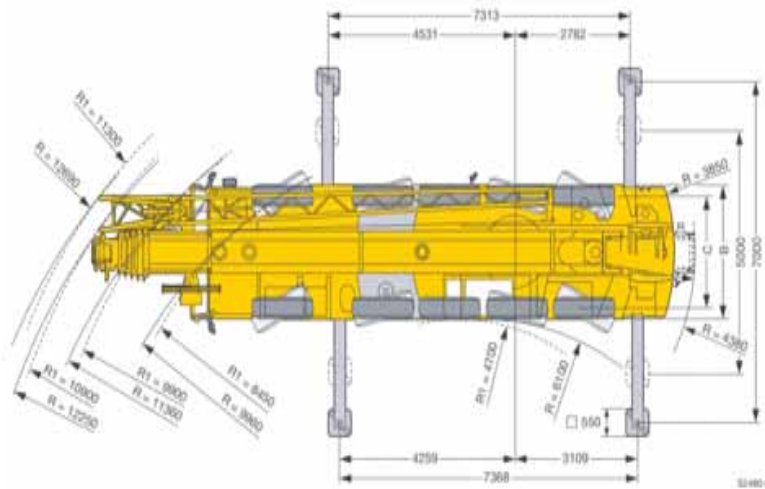

◆ 95 tn mobilinosturi

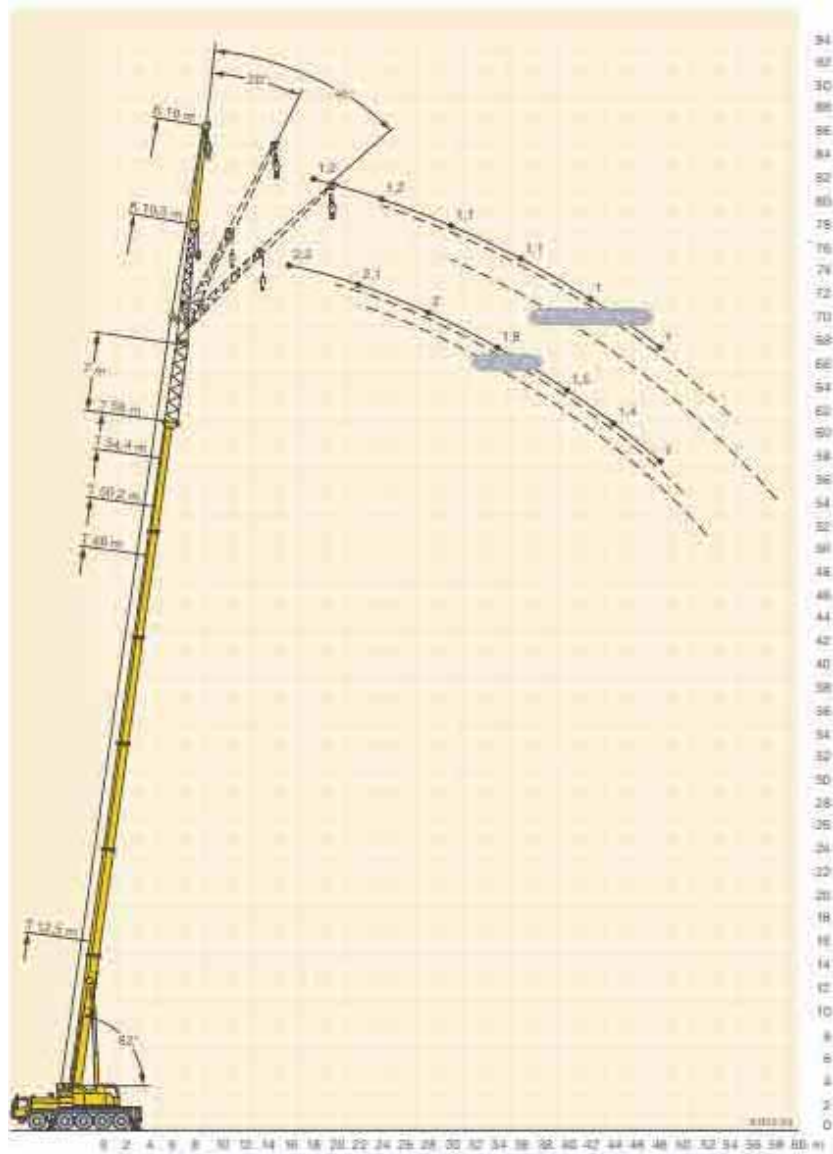

m	12.5 m		16.6 m		20.8 m		25 m		29.2 m		33.4 m		37.6 m		41.8 m		46 m		50.2 m		54.4 m		58 m		
		95	63.3	63.3		60.2		48.5		38		29.9		23		18.1		13.9		10.5		8.3		6.4	
3	74	63.3	63.3		60.2		48.5		38		29.9		23		18.1		13.9		10.5		8.3		6.4		3
3.5	69.5	62.8	62.8		59.3		47.9		37		29.4		22.5		17.6		13.6		10.3		8		6.3		3.5
4	66.3	59.1	58.9		55.9		47.9		38		29.4		21.2		17.6		13.1		10.3		8.1		7.6		4
4.5	60.7	54.2	54.6		53.3		47.2		37.6		29.9		21.2		17.6		13.6		10.5		8.2		6.4		4.5
5	49.7	46.3	46.7		46.8		45.1		36.6		29.4		21.2		17.6		13.1		10.3		8.2		6.4		5
6	41.4	39.9	40.2		40.3		40.1		35.2		28.5		22.5		18.1		13.6		10.5		8.1		7.6		5
7	35.1	34.1	34.5		34.6		34.4		33.8		27.4		21.2		17.6		13.9		10.5		8.3		6.4		6
8	30.2	29.5	30.3		30		30.6		30.4		25.9		20		16.8		13.6		10.5		8.3		6.4		7
9	26.5	26	26.7		26.4		26.9		26.7		24.4		18.8		15.9		13.1		10.3		8.1		7.6		8
10			23.6		23.9		23.9		23.6		23.2		17.6		15		12.6		10		8.2		6.4		9
11			21.1		21.4		21.4		21.1		21.5		16.5		14.1		12.1		9.7		8		6.3		10
12			17.2		17.5		17.4		17.9		17.7		14.6		12.6		11		9.1		7.6		6		11
14					14.9		14.9		14.5		12.9		11.3		9.9		8.4		7.2		6.7		5.7		12
16					12.4		12.4		12.1		11.4		10.2		9		7.7		6.7		5.4		5		13
18					10.6		10.5		10.1		10.1		9.2		8.1		7.2		6.2		5.1		4.8		14
20					9.1		9		8.8		9.1		8.3		7.4		6.6		5.8		4.8		4.8		15
22									7.8		7.9		7.1		6.8		6.1		5.4		4.5		4.5		16
24									6.8		6.9		6.5		6.2		5.6		5		4.3		4.3		17
26									6.3		6		5.9		5.4		5.2		4.7		4		4		18
28									5.6		5.6		5.3		4.8		4.4		3.8		3.8		3.8		19
30													4.7		4.9		4.4		4.1		3.5		3.5		20
32													4.4		4.3		4.1		3.8		3.3		3.3		21
34													4		3.8		3.8		3.5		3.4		3.1		22
36															3.4		3.4		3.3		3		2.9		23
38																	3		2.9		2.6		2.7		24
40																			2.8		2.3		2.3		25
42																					2.3		2		26
44																					2		2		27
46																							1.7		28
48																							1.4		29
50																							1.2		30
52																							1		31
54																							0.8		32

m	12.5 m × 7 m			46 m × 7 m			50.2 m × 7 m			54.4 m × 7 m			57.3 m × 7 m			
	19 m	19 m	19 m	19 m	19 m	19 m	19 m	19 m	19 m	19 m	19 m	19 m	19 m	19 m		
4.5	0°	20°	40°	0°	20°	40°	0°	20°	40°	0°	20°	40°	0°	20°	40°	4.5
5	2.1															5
6	2.1															6
7	2.1															7
8	2.1															8
9	2.1															9
10	2															10
11	2	1.9														11
12	2	1.9														12
14	1.8	1.9			2.1											14
16	1.7	1.8	1.7		2.1			1.8			1.6					16
18	1.5	1.7	1.7		2.1			1.8			1.6			1.2		18
20	1.4	1.5	1.6		2.1			1.8			1.6			1.2		20
22	1.3	1.4	1.5		2			1.8	1.8		1.6			1.2		22
24	1.2	1.2	1.4		2			1.8	1.8		1.6	1.6		1.2	1.2	24
26	1.1	1.1	1.2		1.9	1.8	1.7	1.8	1.8	1.7	1.6	1.6		1.2	1.2	26
28	1	1	1.1		1.9	1.8	1.7	1.8	1.7	1.7	1.6	1.5	1.5	1.2	1.2	28
30	0.9	0.8	0.9		1.8	1.7	1.7	1.7	1.6	1.6	1.5	1.5	1.1	1.2	1.2	30
32	0.8	0.7	0.8		1.7	1.6	1.6	1.7	1.6	1.6	1.5	1.5	1.1	1.2	1.2	32
34	0.7	0.7	0.7		1.6	1.6	1.6	1.6	1.5	1.5	1.5	1.5	1.1	1.2	1.2	34
36	0.6				1.5	1.5	1.5	1.5	1.5	1.5	1.5	1.4	1.5	1.1	1.2	36
38					1.4	1.4	1.4	1.5	1.4	1.4	1.4	1.4	1.1	1.1	1.2	38
40					1.3	1.3	1.3	1.4	1.4	1.4	1.4	1.3	1.4	1	1.2	40
42					1.3	1.3	1.3	1.3	1.3	1.3	1.3	1.3	1	1	1.2	42
44					1.2	1.2	1.2	1.2	1.2	1.2	1.2	1.2	1	1.1	1.1	44
46					1.1	1.1	1.2	1.2	1.2	1.2	1.2	1.2	1	1	1.1	46
48					1	1.1	1.1	1.1	1.1	1.1	1.1	1.1	1	1	1	48
50					1	1	1	1	1	1.1	1	1.1	1.1	0.9	1	50







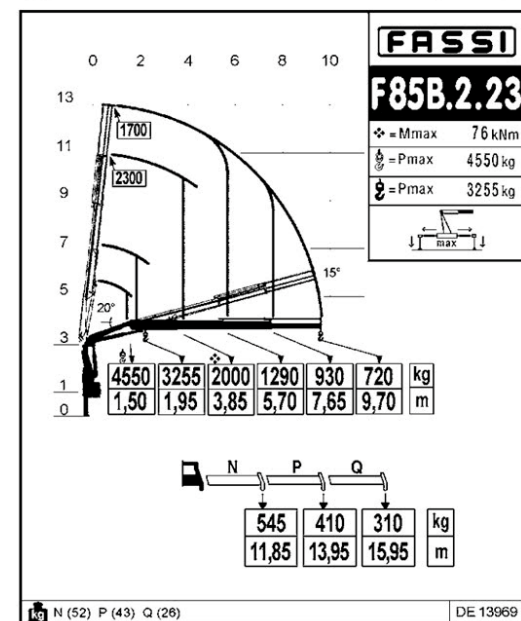
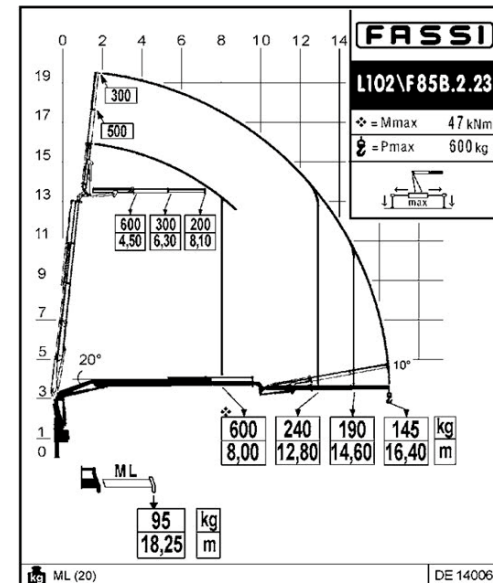

◆ Priimus, 8 t/m mininosturi

3350 kg	3305 mm	18,2 m	2100 mm
2640 mm		19 m	1200 mm



◆ JEKKO JF545

 17200 kg	 6700 mm	 28 m	 2745 mm
 5450 mm		 30 m	 1800 mm

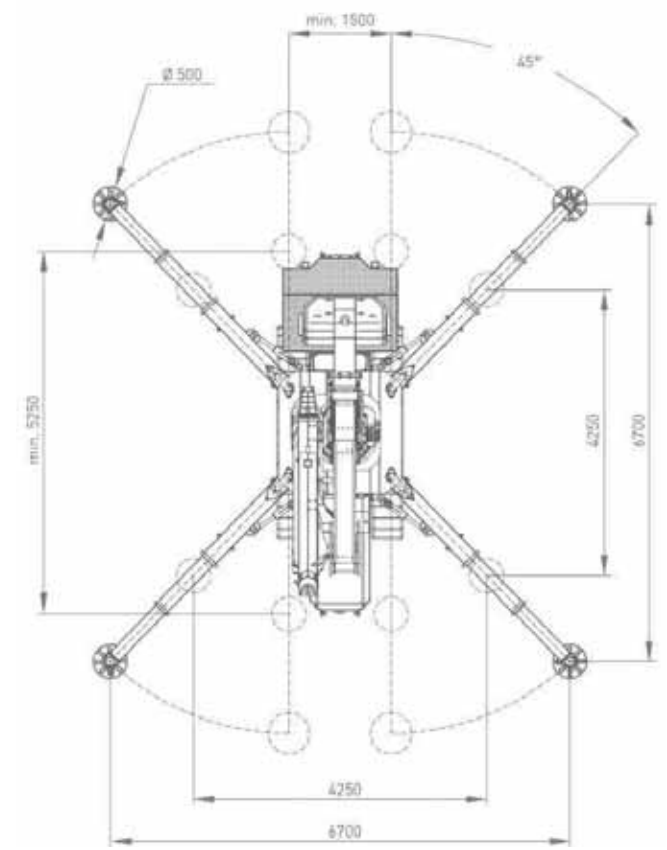
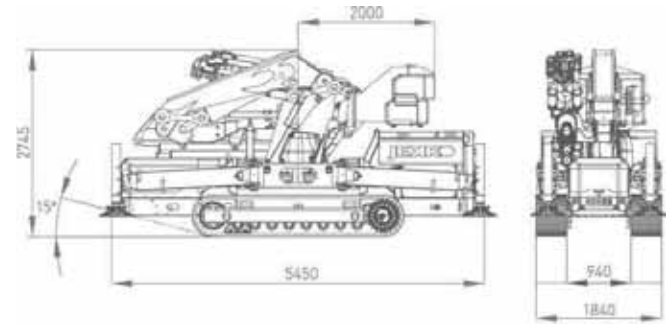
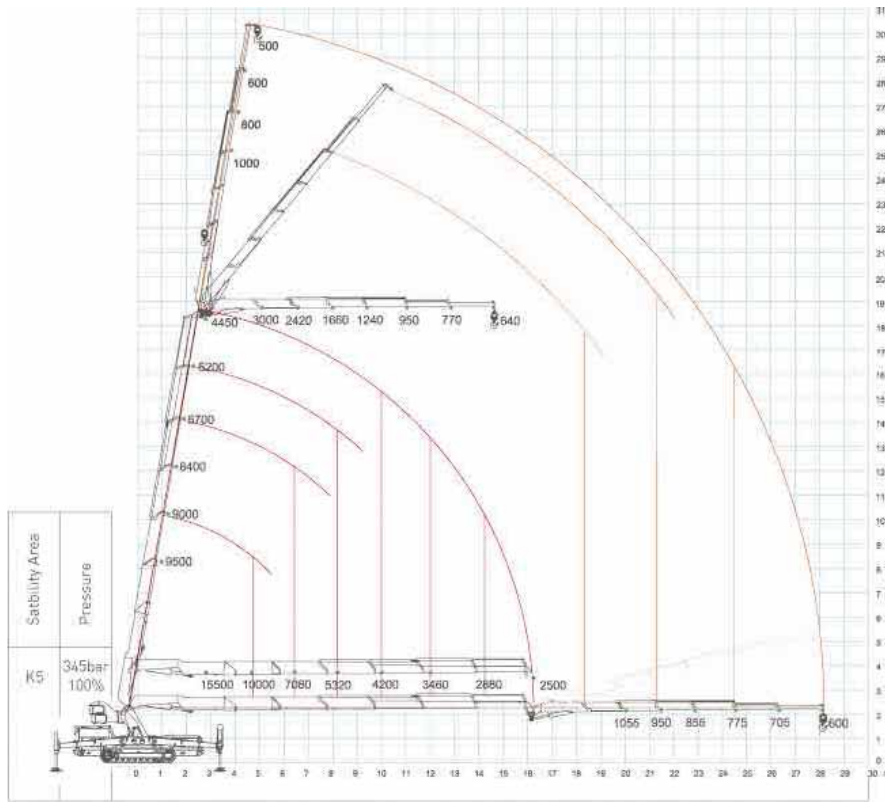







LISÄVARUSTEINA MM.

- Pieni Henki lökori
- Kel luva iso kori
- Imukuppi 450kg saakka
- Imukuppi 450-1000kg
- Koura
- Erilaiset nostopalkit (I-palkki, X-palkki)
- S-rauta / koukun kohottaja
- Kattotuolikoukku
- Kahitiilihäkki
- Lavahaarukka
- Mekaaniset kylmät jatkot
- Jassikka
- Kääntöpyörä
- C-Rauta
- Palkki / putkinostin

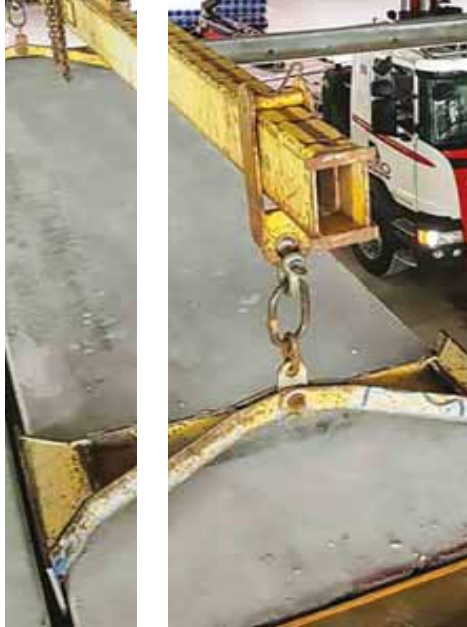



Luotettavaa palvelua



vuodesta 1961

TRAKTORI JA MAANRAKEN-
NUSTOIMIALA MYYDÄÄN JA
INVESTOIDAAN
NOSTOPALVELUIHIN.

TOIMINTA LAAJENEE
JÄRVI-SUOMEN
KASVUKESKUKSIIN.

1961

ELIAS KOPONEN ALOITTA
TYÖSKENTELYN TRAKTOREILLA
JA PYÖRÄKUORMAAILLA
VARKAUDESSA.

SUKUPOLVENVAIHDOS ISÄLTÄ
POJALLE. JUHA KOPONEN ALOITTA
KOKOPÄIVÄTOIMISESTI ISÄNSÄ
PERUSTAMASSA YRITYKSESSÄ.

KUROTTAJAPALVELULIIKETOIMINTA
MYYDÄÄN JA PALVELUTOIMINNAN
PÄÄPAINO SIIRTYY SUURIIN
ASENNUSNOSTURIAUTOIHIN.

KURKO ACADEMY OY ALOITTA
KULJETTAJAKOULUTUKSET.

2010

2014

2016

2020

PALVELU LAAJENEE
NOSTOPALVELUSTA
KUROTTAJAPALVELU-
LIIKETOIMINTAAN.

OMAA KÄYTTÖÖN VALMISTETUT ASE-
NUSNOSTURIAUTOT TUOTTEISTETAAN
JA KURKO CRANE -TUOTEMERKKI SYNTYY
OMAKSI LIIKETOIMINNAKSI. SOLMITAAN
MAAHANTUONTISOPIMUS JEKKO-MINI-
NOSTUREISTA SUOMEEN.



HANNU SEDIG
044 799 2103



JUHA KOPONEN
0400 671 827



JUSSI TAMMENOJA
044 799 2102



KARI PAARNIO
044 558 0551



MIKKO HINTIKKA
040 079 9220



RAMI KOSKELA
044 799 2199



VELI-MATTI KIVINEN
0440 671 827



JOONA SUOMALAINEN
040 489 0313



SEPPO PUDAS
044 799 2166



◆ YMPÄRISTÖVASTUULLISUUS

Haluamme olla kestävä kehityksen edelläkävijä uusien toimintatapojen ja tuotteiden suunnittelussa. Kehittämämme toiminnot ja tuotteet vaikuttavat omalta osaltaan ympäristön hyvinvointiin ja turvallisuuteen.

Valmistamme ja kehitämme aktiivisesti korkealaatuisia ja ympäristöystävällisempiä tuotteita, sekä toimintatapoja. Haluamme varmistaa toiminnallamme kestävä ympäristön ja yhteiskunnan myös tuleville sukupolville.

Käytössämme/valikoimassa on myös nosturiautoja, joita voidaan käyttää sähköllä kun niihin liitetään Kurko Cranen valmistama sähköistysyksikkö.



YHTEYSTIEDOT

HELSINKI, VANTAA JA ESPOO

PUH. +358 44 799 2166

KUOPIO JA VARKAUS

PUH. +358 40 489 0313

JYVÄSKYLÄ

PUH. +358 44 799 2102

TAMPERE

PUH. +358 44 799 2199

LAPPEENRANTA

PUH. +358 44 799 2103



www.kurkokoponen.fi



KURKO
KOPONEN
NOSTOPALVELUIDEN ASiantuntija